



**Handling Tools & Replacement Parts
Index Page**

Slips & Bowls

Ortco Slip & Bowl, 5-1/2"	1
Ortco Slip & Bowl, 4-1/2"	2
TS 100 Slip & Bowl, 3-1/2"	3

Rotary Slips

- Baash Ross DU Slips
 - DU Regular & Long, 4-1/2" 4
 - DU Regular & Long, 5-1/2" 5
 - DU Regular & Long, 7" 6
- Varco Rotary Slips
 - SDS, 3-1/2" & 4-1/2" 7
 - SDML, 3-1/2", 4-1/2", 5" & 5-1/2" 8
 - SDXL, 4-1/2", 5" & 5-1/2" 9
- Woolley Rotary Slips
 - Type B, 4-1/2" Short & Long 10
 - Type B, 5-1/2" Slip 10
 - Type XL Slip 10

Manual Tongs

- BJ Tongs
 - SDD Tong 11
 - DB Tong 12
 - B Tong 13
 - C Tong 14
- Web Wilson Tongs
 - AAX Tong 15
 - AAX Casing Tong 15
 - H, B, C & D Tongs 15

Elevators

- BJ Elevators
 - TA-35, TA-65, TA-100, TA-150. 16-17
 - MG, RG, MGG, GG 18-20
 - SLX-100, 150, 350, 500 21
 - Elevator Bore Code Chart 22

Slip Type Elevator

- BJ Slip Type Elevator
 - LYT Slip Elevator 23
 - MYT Slip Elevator 24
 - YT Slip Elevator 25
 - YC Slip Elevator 26-27

Casing Slips

- Baash Ross UC-3 & UC-4 28
- Varco CMS-XL 29

Drill Collar Slips

- Baash Ross C & C-1 30
- Varco DCS-S, DCS-R, DCS-L 31
- Woolley Type A Drill Collar Slip 31

Safety Clamps.

- Baash Ross Type C 32
- Baash Ross Type T 33
- Varco MP-S, MP-R, MP-M, MP-L, MP-XL . . . 34
- Varco MP Replacement Parts 35

Tubing Spiders

- BJ
 - 50 Ton 37
 - 100 Ton 37
- Cavins
 - Model B 38-39
 - Model C 38-39
- GS-60 40-42
- Guiberson T-60 (F-1) 43
- Oil Country Type G 44

Sucker Rod Elevators

- Solid & Plate Type Rod Elevator. 45



Ortco 5-1/2" Bowl & Slip

Cat. #	Ref. #	Description	Wt. Ea.	Qty. Req.	Box
Bowl & Slip Assemblies					
010-0200	N/A	Bowl, 5-1/2"	213.0	1	A/R
010-1010	N/A	Slip Assembly, 5-1/2" (Less Inserts)	70.0	1	A/R
Replacement Parts					
010-1210	N/A	Slip Handle Assembly	21.0	1	A/R
010-1410	N/A	Slip Segment (Set of 6)	8.0	1	A/R
010-1800	N/A	Insert Retainer Screw	0.2	6	A/R
010-9710	N/A	Segment Retainer Screw	0.3	6	A/R
010-1100	N/A	Hinge Pin	4.0	1	A/R
010-7910	N/A	Pull Pin with Chain	4.5	1	A/R
Replacement Inserts					
12-2908	N/A	Insert for Slips, 5-1/2" x 2-7/8"	2.8	12	12
12-2909	N/A	Insert for Slips, 5-1/2" x 3"	2.8	12	12
12-2910	N/A	Insert for Slips, 5-1/2" x 3-1/8"	2.5	12	12
12-2911	N/A	Insert for Slips, 5-1/2" x 3-1/4"	2.1	12	12
12-2913	7613-E-82	Insert for Slips, 5-1/2" x 3-1/2"	2.3	12	12
12-2915	N/A	Insert for Slips, 5-1/2" x 3-3/4"	2.2	12	12
12-2917	7613-D-81	Insert for Slips, 5-1/2" x 4"	2.0	12	12
12-2918	N/A	Insert for Slips, 5-1/2" x 4-1/8"	2.1	12	12
12-2919	N/A	Insert for Slips, 5-1/2" x 4-1/4"	2.0	12	12
12-2920	N/A	Insert for Slips, 5-1/2" x 4-3/8"	2.0	12	12
12-2921	7613-E-81	Insert for Slips, 5-1/2" x 4-1/2"	2.0	12	12
12-2923	7613-F-81	Insert for Slips, 5-1/2" x 4-3/4"	2.0	12	12
12-2925	7613-G-81	Insert for Slips, 5-1/2" x 5"	1.5	12	12
12-2929	7613-H-81	Insert for Slips, 5-1/2" x 5-1/2"	1.0	12	12

Ortco 4-1/2" Bowl & Slip

Cat. #	Ref. #	Description	Wt. Ea.	Qty. Req.	Box
Bowl & Slip Assemblies					
020-0200	N/A	Bowl, 4-1/2"	155.0	1	A/R
020-1400	N/A	Slip Assembly, 4-1/2" (Less Inserts)	60.0	1	A/R
Replacement Parts					
020-1200	N/A	Slip Handle Assembly, 4-1/2"	20.0	1	A/R
020-1400	N/A	Slip Segments (Set of 6)	40.0	1	A/R
020-1800	N/A	Insert Retainer Pin with Cotter	0.2	6	A/R
020-9700	N/A	Segment Retainer Screw	0.2	6	A/R
020-1100	N/A	Hinge Pin for 4-1/2" Slip	3.5	1	A/R
020-7900	N/A	Pull Pin with Chain	3.8	1	A/R
Replacement Inserts					
12-2104	7613-H-82	Insert for Slips, 4-1/2" x 1-1/2"	2.7	12	12
12-2105	7613-N-82	Insert for Slips, 4-1/2" x 2"	2.5	12	12
12-2106	7613-M-82	Insert for Slips, 4-1/2" x 2-1/16"	2.5	12	12
12-2107	7613-A-82	Insert for Slips, 4-1/2" x 2-3/8"	2.2	12	12
12-2108	7613-B-82	Insert for Slips, 4-1/2" x 2-7/8"	2.0	12	12
12-2110	N/A	Insert for Slips, 4-1/2" x 3-1/8"	1.5	12	12
12-2113	7613-C-82	Insert for Slips, 4-1/2" x 3-1/2"	1.5	12	12
12-2115	N/A	Insert for Slips, 4-1/2" x 3-3/4"	1.5	12	12
12-2117	7613-FF-81	Insert for Slips, 4-1/2" x 4"	1.0	12	12
12-2121	7613-A-81	Insert for Slips, 4-1/2" x 4-1/2"	0.7	12	12



3-1/2" (TS-100) Bowl & Slip

Cat. #	Ref. #	Description	Wt. Ea.	Qty. Req.	Box
Bowl & Slips Assemblies					
030-0200	7502-100	Tubing Spider Bowl, 3-1/2"	187.0	1	A/R
030-1000	7502-104	Slip Assembly, 3-1/2" (Less Inserts)	51.0	1	A/R
Replacement Parts					
030-1400	7502-C-217	Right Segment	13.0	1	A/R
030-1405	7502-B-217	Center Segment	13.0	1	A/R
030-1410	7502-A-217	Left Segment	13.0	1	A/R
030-1100	7502-A-216	Hinge Pin with Cotter	0.4	2	A/R
030-7900	7502-D-203	Lock Pin with Bail & Chain	5.0	1	A/R
030-1105	7502-A-202	Hinge Pin for Bowl	2.0	1	A/R
030-2000	7502-A-207	Latch	0.5	1	A/R
030-1200	7502-A-214	Latch Handle	3.0	1	A/R
030-7905	7502-B-207	Latch Pin with Cotter	0.5	1	A/R
030-9500	7502-C-207	Latch Spring	0.2	2	A/R
030-1800	7502-B-216	Liner Retainer Pin with Cotter	0.2	3	A/R
030-1700	7502-203-X	Retaining Ring for Bowl Hinge Pin	0.5	1	A/R
Replacement Inserts					
030-1301	7502-A-5077	Insert for Slips, 3-1/2" x 3/4"	2.1	9	9
030-1302	7502-A-5076	Insert for Slips, 3-1/2" x 1"	2.7	9	9
030-1303	7502-A-5075	Insert for Slips, 3-1/2" x 1-1/4"	2.5	9	9
030-1304	7502-A-5074	Insert for Slips, 3-1/2" x 1-1/2"	2.2	9	9
030-1305	7502-A-5073	Insert for Slips, 3-1/2" x 2"	2.0	9	9
030-1306	7502-A-5072	Insert for Slips, 3-1/2" x 2-1/16"	2.0	9	9
030-1307	7502-A-5071	Insert for Slips, 3-1/2" x 2-3/8"	1.7	9	9
030-1308	7502-A-5070	Insert for Slips, 3-1/2" x 2-7/8"	1.5	9	9
030-1309	N/A	Insert for Slips, 3-1/2" x 3"	1.2	9	9
030-1310	N/A	Insert for Slips, 3-1/2" x 3-1/8"	1.1	9	9
030-1311	N/A	Insert for Slips, 3-1/2" x 3-1/4"	1.1	9	9
030-1312	N/A	Insert for Slips, 3-1/2" x 3-3/8"	1.2	9	9
030-1313	7502-A-5069	Insert for Slips, 3-1/2" x 3-1/2"	1.2	9	9

Baash Ross 4-1/2" DU Regular & Long Rotary Slips

Cat. #	Ref. #	Description	Wt. Ea.	Qty. Req.	Box
4-1/2" Rotary Slips					
100-1000	7613-59	DU Regular Slip with Steel Handles (Less Inserts), 4-1/2"	123.0	1	A/R
100-1005	7613-5041	DU Regular Slip with Safety Handles (Less Inserts), 4-1/2"	123.0	1	A/R
101-1000	7613-64	DU Long Slip with Steel Handles (Less Inserts), 4-1/2"	150.0	1	A/R
101-1010	7613-5044	DU Long Slip with Safety Handle (Less Inserts), 4-1/2"	150.0	1	A/R
Replacement Parts					
12-1200-1	7613-A-157	Universal Handle for DU Slips	4.0	1	A/R
12-1200-2	7613-5187	Front Handle	4.0	2	A/R
12-1200-3	7613-5195	Stirrup (Rear) Handle	4.0	1	A/R
12-1205-03	7613-5190	Set, Universal Safety Flex Handles (3 pcs)	18.	1	A/R
12-1300	7613-B-12	Handle Pin, Front	0.2	2	A/R
12-1305	7613-C-12	Handle Pin, Rear	3.7	1	A/R
12-1105	7613-A-12	Hinge Pin with Cotter	1.2	2	A/R
12-9500	7613-211	Hinge Spring Assembly	1.2	2	A/R
12-1800*	7613-A-52	Liner Retainer Key for DU Regular Slips	1.5	3	A/R
12-1810*	7613-A-67	Liner Retainer Key for DU Long Slip	1.7	3	A/R
*Oversized Liner Keys available in .010", .020" & .030".					
Replacement Inserts					
12-2103	N/A	Insert for Slips, 4-1/2" x 1-1/4"	2.8	18 Reg / 24 Long	A/R
12-2104	7613-H-82	Insert for Slips, 4-1/2" x 1-1/2"	2.7	18 Reg / 24 Long	A/R
12-2105	7613-N-82	Insert for Slips, 4-1/2" x 2"	2.5	18 Reg / 24 Long	A/R
12-2106	7613-M-82	Insert for Slips, 4-1/2" x 2-1/16"	2.5	18 Reg / 24 Long	A/R
12-2107	7613-A-82	Insert for Slips, 4-1/2" x 2-3/8"	2.2	18 Reg / 24 Long	A/R
12-2108	7613-B-82	Insert for Slips, 4-1/2" x 2-7/8"	2.0	18 Reg / 24 Long	A/R
12-2110	N/A	Insert for Slips, 4-1/2" x 3-1/8"	1.5	18 Reg / 24 Long	A/R
12-2113	7613-C-82	Insert for Slips, 4-1/2" x 3-1/2"	1.5	18 Reg / 24 Long	A/R
12-2117	7613-FF-81	Insert for Slips, 4-1/2" x 4"	1.0	18 Reg / 24 Long	A/R
12-2119	N/A	Insert for Slips, 4-1/2" x 4-1/4"	0.8	18 Reg / 24 Long	A/R
12-2121	7613-A-81	Insert for Slips, 4-1/2" x 4-1/2"	0.7	18 Reg / 24 Long	A/R



Baash Ross 5-1/2" DU Regular & Long Rotary Slips

Cat. #	Ref. #	Description	Wt. Ea.	Qty. Req.	Box
Replacement Parts					
12-1200-1	7613-A-157	Universal Handle	4.0	1	A/R
12-1200-2	7613-5187	Front Handle	4.0	2	A/R
12-1200-3	7613-5159	Stirrup (Rear) Handle	4.0	1	A/R
12-1205-03	7613-5190	Set, Universal Safety Flex Handles (3 pcs)	18.	1	A/R
12-1300	7613-B-12	Handle Pin, Front	0.2	2	A/R
12-1305	7613-C-12	Handle Pin, Rear	0.3	1	A/R
12-1105	7613-A-12	Hinge Pin with Cotter	1.2	2	A/R
12-9500	7613-211	Hinge Spring Assembly	1.2	2	A/R
12-1800*	7613-A-52	Liner Retainer Key For DU Regular Slips	1.5	3	A/R
12-1810*	7613-A-67	Liner Retainer Key For DU Long Slip	1.7	3	A/R

*Oversized Liner Keys available in .010", .020" & .030".

Replacement Inserts					
12-2908	N/A	Insert for Slips, 5-1/2" x 2-7/8"	2.8	18 Reg / 24 Long	18/24
12-2909	N/A	Insert for Slips, 5-1/2" x 3"	2.8	18 Reg / 24 Long	A/R
12-2910	N/A	Insert for Slips, 5-1/2" x 3-1/8"	2.5	18 Reg / 24 Long	A/R
12-2911	N/A	Insert for Slips, 5-1/2" x 3-1/4"	2.1	18 Reg / 24 Long	A/R
12-2913	7613-E-82	Insert for Slips, 5-1/2" x 3-1/2"	2.2	18 Reg / 24 Long	A/R
12-2915	N/A	Insert for Slips, 5-1/2" x 3-3/4"	2.1	18 Reg / 24 Long	A/R
12-2917	7613-D-81	Insert for Slips, 5-1/2" x 4"	2.1	18 Reg / 24 Long	A/R
12-2918	N/A	Insert for Slips, 5-1/2" x 4-1/8"	2.1	18 Reg / 24 Long	A/R
12-2919	N/A	Insert for Slips, 5-1/2" x 4-1/4"	2.0	18 Reg / 24 Long	A/R
12-2920	N/A	Insert for Slips, 5-1/2" x 4-3/8"	2.0	18 Reg / 24 Long	A/R
12-2921	7613-E-81	Insert for Slips, 5-1/2" x 4-1/2"	2.0	18 Reg / 24 Long	A/R
12-2923	7613-F-81	Insert for Slips, 5-1/2" x 4-3/4"	2.0	18 Reg / 24 Long	A/R
12-2925	7613-G-81	Insert for Slips, 5-1/2" x 5"	1.5	18 Reg / 24 Long	A/R
12-2929	7613-H-81	Insert for Slips, 5-1/2" x 5-1/2"	1.0	18 Reg / 24 Long	A/R



Baash Ross 7" DU Regular & Long Rotary Slips

Cat. #	Ref. #	Description	Wt. Ea.	Qty. Req.	Box
Replacement Parts					
12-1200-1	7613-A-157	Universal Handle	4.0	1	A/R
12-1200-2	7613-5187	Front Handle	4.0	2	A/R
12-1200-3	7613-5159	Stirrup (Rear) Handle	4.0	1	A/R
12-1205-03	7613-5190	Set, Universal Safety Flex Handles (3 pcs)	18.	1	A/R
12-1300	7613-B-12	Handle Pin, Front	0.2	2	A/R
12-1305	7613-C-12	Handle Pin, Rear	0.3	1	A/R
12-9500	7613-211	Hinge Spring Assembly	1.2	2	A/R
12-1105	7613-A-12	Hinge Pin with Cotter	1.2	2	A/R
12-1800*	7613-A-52	Liner Retainer Key For DU Regular Slips	1.5	3	A/R
12-1810*	7613-A-67	Liner Retainer Key For DU Long Slip	1.7	3	A/R

*Oversized Liner Keys available in .010", .020" & .030".

Replacement Inserts					
12-3821	7613-W-81	Insert for Slips, 7" x 4-1/2"	4.2	18 Reg / 24 Long	A/R
12-3825	7613-Y-81	Insert for Slips, 7" x 5"	3.7	18 Reg / 24 Long	A/R
12-3829	7613-Z-81	Insert for Slips, 7" x 5-1/2"	3.2	18 Reg / 24 Long	A/R
12-3831	7613-BB-81	Insert for Slips, 7" x 5-3/4"	3.1	18 Reg / 24 Long	A/R
12-3833	7613-CC-81	Insert for Slips, 7" x 6"	2.5	18 Reg / 24 Long	A/R
12-3835	7613-DD-81	Insert for Slips, 7" x 6-5/8"	1.7	18 Reg / 24 Long	A/R
12-3838	7613-EE-81	Insert for Slips, 7" x 7"	1.2	18 Reg / 24 Long	A/R



Varco SDS Rotary Slips

Cat. #	Ref. #	Description	Wt. Ea.	Qty. Req.	Box
3-1/2" Rotary Slips					
110-1000	3912	SDS Slip Complete (Less Inserts), 3-1/2"	109.0	1	A/R
110-1007	3901	SDS Slip Complete (with Inserts), 3-1/2" x 2-3/8"	117.0	1	A/R
110-1008	3903	SDS Slip Complete (with Inserts), 3-1/2" x 2-7/8"	111.0	1	A/R
110-1013	3905	SDS Slip Complete (with Inserts), 3-1/2" x 3-1/2"	117.0	1	A/R
4-1/2" Rotary Slips					
111-1000	3906	SDS Slip Complete (Less Inserts), 4-1/2"	115.0	1	A/R
111-1013	3907	SDS Slip Complete (with Inserts), 4-1/2" x 3-1/2"	143.0	1	A/R
111-1017	3909	SDS Slip Complete (with Inserts), 4-1/2" x 4"	136.0	1	A/R
111-1021	3911	SDS Slip Complete (with Inserts), 4-1/2" x 4-1/2"	127.0	1	A/R
Replacement Parts					
36-3767	3767	Right Handle	3.5	1	A/R
36-3766	3766	Center/Rear Handle	4.0	1	A/R
36-3768	3768	Left Handle	3.5	1	A/R
36-1200-03	NA	Set, Safety Flex Handles (3 pcs)	12.	1	A/R
36-3769	3769	Handle Pin with Cotter & Washer	0.5	3	A/R
36-2190	2190	Hinge Pin with Cotter Pin	1.2	2	A/R
36-3738	3738	Insert Retainer Ring, 3-1/2"	1.0	3	A/R
36-3739	3739	Insert Retainer Ring, 4-1/2"	1.0	3	A/R
36-3737	3737	Kit, 6 Bolts & Nuts & 1 Allen Wrench	0.2	1	A/R
3-1/2" Replacement Inserts					
36-2160	2160	Insert for Varco Slips, 3-1/2" x 2-3/8"	0.9	24	24
36-2161	2161	Insert for Varco Slips, 3-1/2" x 2-7/8"	0.6	24	24
36-2162	2162	Insert for Varco Slips, 3-1/2" x 3-1/2"	0.4	24	24
4-1/2" Replacement Inserts					
36-2163	2163	Insert for Varco Slips, 4-1/2" x 3-1/2"	0.9	36	36
36-2164	2164	Insert for Varco Slips, 4-1/2" x 4"	0.6	36	36
36-2165	2165	Insert for Varco Slips, 4-1/2" x 4-1/2"	0.4	36	36

Varco SDML Rotary Slips

Cat. #	Ref. #	Description	Wt. Ea.	Qty. Req.	Box
3-1/2", 4-1/2", 5" and 5-1/2" Rotary Slips					
112-1000	15522-1	SDML Slip Complete (Less Inserts), 3-1/2"	170.0	1	A/R
112-1007	15524	SDML Slip Complete (with Inserts), 3-1/2" x 2-3/8"	193.0	1	A/R
112-1008	15523	SDML Slip Complete (with Inserts), 3-1/2" x 2-7/8"	188.0	1	A/R
112-1013	15522	SDML Slip Complete (with Inserts), 3-1/2" x 3-1/2"	180.0	1	A/R
113-1000	15565-1	SDML Slip Complete (Less Inserts), 4-1/2"	173.0	1	A/R
113-1013	15563	SDML Slip Complete (with Inserts), 4-1/2" x 3-1/2"	207.0	1	A/R
113-1017	15564	SDML Slip Complete (with Inserts), 4-1/2" x 4"	199.0	1	A/R
113-1021	15565	SDML Slip Complete (with Inserts), 4-1/2" x 4-1/2"	188.0	1	A/R
114-1000	15569-1	SDML Slip Complete (Less Inserts), 5"	170.0	1	A/R
114-1017	15567	SDML Slip Complete (with Inserts), 5" x 4"	204.0	1	A/R
114-1021	15568	SDML Slip Complete (with Inserts), 5" x 4-1/2"	196.0	1	A/R
114-1025	15569	SDML Slip Complete (with Inserts), 5" x 5"	204.0	1	A/R
115-1000	15573-1	SDML Slip Complete (Less Inserts), 5-1/2"	166.0	1	A/R
115-1021	15571	SDML Slip Complete (with Inserts), 5-1/2" x 4-1/2"	200.0	1	A/R
115-1025	15572	SDML Slip Complete (with Inserts), 5-1/2" x 5"	192.0	1	A/R
115-1029	15573	SDML Slip Complete (with Inserts), 5-1/2" x 5-1/2"	181.0	1	A/R
Replacement Parts					
36-3767	3767	Right Handle	3.5	1	A/R
36-3766	3766	Center/Rear Handle	4.0	1	A/R
36-3768	3768	Left Handle	3.5	1	A/R
36-1200-03	NA	Set, Safety Flex Handles (3 pcs)	12.	1	A/R
36-3769	3769	Handle Pin with Cotter & Washer	0.5	3	A/R
36-2192	2192	Hinge Pin with Cotter	1.2	2	A/R
36-3738	3738	Insert Retainer Ring, 3-1/2'	1.0	3	A/R
36-3739	3739	Insert Retainer Ring, 4-1/2"	1.0	3	A/R
36-3741	3741	Insert Retainer Ring, 5"	1.0	3	A/R
36-3740	3740	Insert Retainer Ring, 5-1/2"	1.2	3	A/R
36-3745	3745	Insert Retainer Screw with Washer	0.3	6	A/R
36-3737	3737	Kit, 6 Bolts & Nuts & 1 Allen Wrench	0.3	1	A/R
3-1/2" Replacement Inserts					
36-2160	2160	Insert for Slips, 3-1/2" x 2-3/8"	0.9	30	30
36-2161	2161	Insert for Slips, 3-1/2" x 2-7/8"	0.6	30	30
36-2162	2162	Insert for Slips, 3-1/2" x 3-1/2"	0.4	30	30
4-1/2" Replacement Inserts					
36-2163	2163	Insert for Slips, 4-1/2" x 3-1/2"	0.9	45	45
36-2164	2164	Insert for Slips, 4-1/2" x 4"	0.6	45	45
36-2165	2165	Insert for Slips, 4-1/2" x 4-1/2"	0.4	45	45
5" & 5-1/2" Replacement Inserts					
36-2168	2168	Insert for Slips, 5" x 4"	0.9	45	45
36-2166	2166	Insert for Slips, 5" x 4-1/2"	0.6	45	45
36-2167	2167	Insert for Slips, 5" x 5"	0.4	45	45
36-2168	2168	Insert for Slips, 5-1/2" x 4-1/2"	0.9	45	45
36-2169	2169	Insert for Slips, 5-1/2" x 5"	0.6	45	45
36-2170	2170	Insert for Slips, 5-1/2" x 5-1/2"	0.4	45	45



Varco SDXL Rotary Slips

Cat. #	Ref. #	Description	Wt. Ea.	Qty. Req.	Box
4-1/2", 5" and 5-1/2" Rotary Slips					
116-1000	15562	SDXL Slips Complete (Less Inserts), 4-1/2"	182.0	1	A/R
116-1013	15515V	SDXL Slips Complete (with Inserts), 4-1/2" x 3-1/2"	229.0	1	A/R
116-1017	15514	SDXL Slips Complete (with Inserts), 4-1/2" x 4"	219.0	1	A/R
116-1021	15513V	SDXL Slips Complete (with Inserts), 4-1/2" x 4-1/2"	205.0	1	A/R
117-1000	15566	SDXL Slips Complete (Less Inserts), 5"	193.0	1	A/R
117-1017	15518	SDXL Slips Complete (with Inserts), 5" x 4"	237.0	1	A/R
117-1021	15517	SDXL Slips Complete (with Inserts), 5" x 4-1/2"	227.0	1	A/R
117-1025	15516V	SDXL Slips Complete (with Inserts), 5" x 5"	213.0	1	A/R
118-1000	15570	SDXL Slips Complete (Less Inserts), 5-1/2"	193.0	1	A/R
118-1017	15521	SDXL Slips Complete (with Inserts), 5-1/2" x 4-1/2"	234.0	1	A/R
118-1025	15520	SDXL Slips Complete (with Inserts), 5-1/2" x 5"	221.0	1	A/R
118-1029	15519V	SDXL Slips Complete (with Inserts), 5-1/2" x 5-1/2"	210.0	1	A/R
Replacement Parts					
36-3767	3767	Right Handle	3.5	1	A/R
36-3766	3766	Center/Rear Handle	4.0	1	A/R
36-3768	3768	Left Handle	3.5	1	A/R
36-1200-03	NA	Set, Safety Flex Handles (3 pcs)	12.	1	A/R
36-3769	3769	Handle Pin with Cotter & Washer	0.5	3	A/R
36-2192	2192	Hinge Pin with Cotter	1.2	2	A/R
36-3739	3739	Insert Retainer Ring, 4-1/2"	1.0	3	A/R
36-3741	3741	Insert Retainer Ring, 5"	1.0	3	A/R
36-3740	3740	Insert Retainer Ring, 5-1/2"	1.2	3	A/R
36-3745	3745	Insert Retainer Screw with Washer	0.3	6	A/R
36-3737	3737	Kit, 6 Bolts & Nuts & 1 Allen Wrench	0.3	1	A/R
4-1/2" Replacement Inserts					
36-2163	2163	Insert for Varco Slips, 4-1/2" x 3-1/2"	0.9	54	54
36-2164	2164	Insert for Varco Slips, 4-1/2" x 4"	0.6	54	54
36-2165	2165	Insert for Varco Slips, 4-1/2" x 4-1/2"	0.4	54	54
5" Replacement Inserts					
36-2168	2168	Insert for Varco Slips, 5" x 4"	0.9	54	54
36-2166	2166	Insert for Varco Slips, 5" x 4-1/2"	0.6	54	54
36-2167	2167	Insert for Varco Slips, 5" x 5"	0.4	54	54
5-1/2" Replacement Inserts					
36-2168	2168	Insert for Varco Slips, 5-1/2" x 4-1/2"	0.9	54	54
36-2169	2169	Insert for Varco Slips, 5-1/2" x 5"	0.6	54	54
36-2170	2170	Insert for Varco Slips, 5-1/2" x 5-1/2"	0.4	54	54

4-1/2" & 5-1/2" Woolley B Rotary Slips

Cat. #	Ref. #	Description	Wt. Ea.	Qty. Req.	Box
4-1/2" Rotary Slips					
120-1000	738-144-0100	Short Slip, 4-1/2" Complete (Less Inserts)	99.0	1	A/R
121-1000	N/A	Long Slip, 4-1/2" Complete (Less Inserts)	114.0	1	A/R
4-1/2" & 5-1/2" Replacement Parts					
42-1200	737-000-0300	Right Handle for 4-1/2" & 5-1/2" B Slips	5.0	1	A/R
42-1205	737-000-0200	Center Handle for 4-1/2" & 5-1/2" B Slips	5.0	1	A/R
42-1210	737-000-0100	Left Handle for 4-1/2" & 5-1/2" B Slips	5.0	1	A/R
42-1250-03	737-100-0203	Set, Safety Flex Handles (3 pcs)	15.	1	A/R
42-1100	737-000-0500	Hinge Pin for 4-1/2" & 5-1/2" B Slips	1.0	2	A/R
42-1300	737-000-0400	Handle Pin for 4-1/2" & 5-1/2" B Slips	0.2	3	A/R
42-1800	737-000-0600	Insert Retainer Pin for 4-1/2" & 5-1/2" B Slips	0.2	3	A/R
4-1/2" Replacement Inserts					
120-2106	N/A	Insert for Woolley Type B, 4-1/2" x 2-1/16"	2.5	18 Reg / 24 Long	A/R
120-2107	757-044-0123	Insert for Woolley Type B, 4-1/2" x 2-3/8"	2.2	18 Reg / 24 Long	A/R
120-2108	757-044-0127	Insert for Woolley Type B, 4-1/2" x 2-7/8"	2.0	18 Reg / 24 Long	A/R
120-2113	757-044-0134	Insert for Woolley Type B, 4-1/2" x 3-1/2"	1.6	18 Reg / 24 Long	A/R
120-2117	757-044-0140	Insert for Woolley Type B, 4-1/2" x 4"	1.2	18 Reg / 24 Long	A/R
120-2121	757-044-0144	Insert for Woolley Type B, 4-1/2" x 4-1/2"	0.8	18 Reg / 24 Long	A/R
5-1/2" Replacement Inserts					
122-2917	757-054-0140	Insert for Woolley Type B, 5-1/2" x 4"	3.0	24	24
122-2921	757-054-0144	Insert for Woolley Type B, 5-1/2" x 4-1/2"	2.3	24	24
122-2925	757-054-0150	Insert for Woolley Type B, 5-1/2" x 5"	2.0	24	24
122-2929	757-054-0154	Insert for Woolley Type B, 5-1/2" x 5-1/2"	1.3	24	24

4-1/2" & 5" Woolley XL Rotary Slips

Cat. #	Ref. #	Description	Wt. Ea.	Qty. Req.	Box
4-1/2" & 5" Replacement Parts					
42-1105	737-344-0500	Hinge Pin for Woolley XL Slips	1.0	2	A/R
42-1805	737-000-1100	Insert Retaining Pin	0.5	3	A/R
42-1230-03	NA	Set, Safety Flex Handles (3 pcs)	12.	1	A/R
4-1/2" Replacement Inserts					
123-2113	757-044-0334	Insert, 4-1/2" x 3-1/2"	3.5	24	24
123-2117	757-044-0340	Insert, 4-1/2" x 4"	1.8	24	24
123-2121	757-044-0344	Insert, 4-1/2" x 4-1/2"	1.3	24	24
5" Replacement Inserts					
124-2517	757-050-0340	Insert, 5" x 4"	2.2	24	24
124-2521	757-050-0344	Insert, 5" x 4-1/2"	1.8	24	24
124-2525	757-050-0350	Insert, 5" x 5"	1.4	24	24



SDD Manual Tong

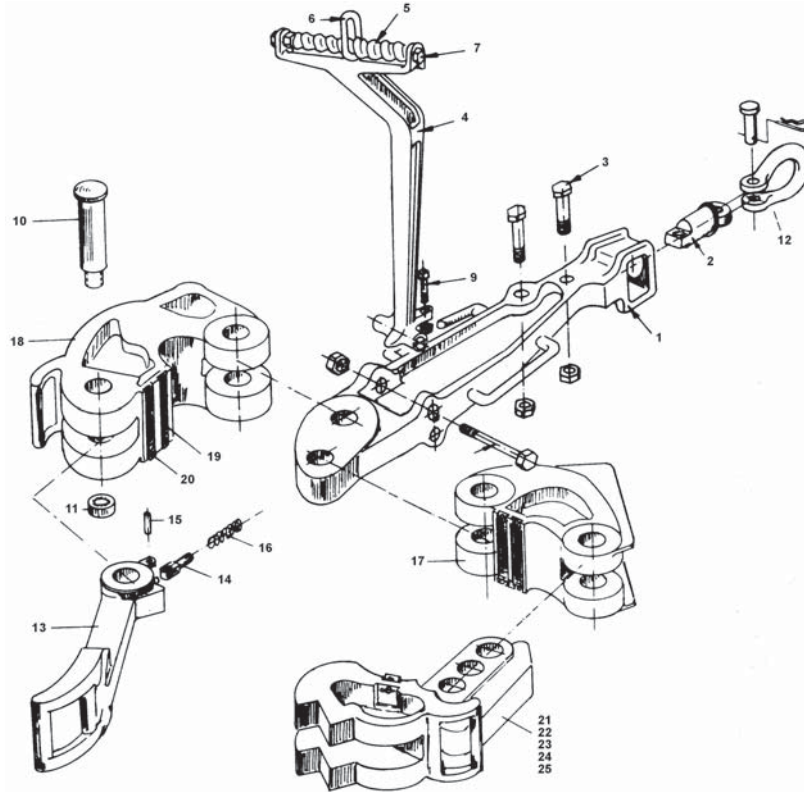

The SDD Tong covers drill pipe or casing sizes from 4" to 17" OD. This Tong is made from alloy steel, heat treated and magnetic particle inspected. All steel specifications are certified. The SDD Tong is rated for 100,000 FT/LBS. Torque.

CAT. #	OEM #	DESCRIPTION	QTY REQ	WT/LBS
131-1000	31054	Tong Complete with Long Lever (Less Lug Jaws)	1	528.00

Item #	Cat #	Ref #	Description	Qty	Wt/Lbs	Item #	Cat #	Ref #	Description	Qty	Wt/Lbs
	131-2100	31055-1	Lever Assembly	1	191.0	12	10-9940	N/A	Clevis Assembly (BVM - Optional)	1	2.00
1	131-2105	31055	Lever	1	183.0		131-2005	31058-1	Latch Assembly	1	48.0
2	10-1920	24529	Tong Line Retainer (BJ - Woolley)	1	1.60	13	131-2000	31058	Latch	1	47.0
	10-2400	24249	Tong Line Retainer Bolt (BJ - Woolley)	1	1.20	14	10-7910	24526	Latch Spring Plunger	1	1.20
2	131-9700	55653	Tong Line Pin (BVM)	1	7.00	15	10-7920	24530	Latch Spring Plunger Pin	1	0.50
3	131-9705	55654	Tong Line Pin Nut & Bolt	1	1.00	16	10-9510	24525	Latch Spring	1	0.20
	10-6800	26782	Hanger Assembly	1	56.0	17	131-5515	31057-1	Short Jaw Assembly	1	88.0
4	10-6810	26783	Hanger	1	45.0	18	131-5510	31056-1	Long Jaw Assembly	1	140.0
5	10-9700	12586	Hanger Balancing Screw	1	3.00	19	52-0170	16401-2	Tong Die, 1/2" x 1-1/4" x 5	3	0.75
6	10-9900	12863	Suspension Ring	1	1.00	20	10-1800	17194	Tong Die Retainer Pin	6	0.10
7	10-9760	939055-576	Hanger Balancing Screw Bolt	1	0.50	21	131-5600	31059-1	Lug Jaw, 4" to 8-1/2"	1	138.0
	10-9725	939484-8	Hanger Balancing Screw Bolt Nut	1	0.30	22	131-5605	31060	Lug Jaw, 8-1/2" to 12"	1	97.0
8	97-35-2824-33	939107-551	Hanger Bolt	1	1.00	23	131-5610	31061	Lug Jaw, 12" to 15"	1	130.0
	97-44-2800-33	940985-8	Hanger Bolt Nut	1	0.50	24	131-5615	31063	Lug Jaw, 15-3/4"	1	156.0
9	97-87-2828-33	939168-133	Hanger Adjustment Screw	1	0.80	25	131-5620	31062	Lug Jaw, 16" to 17"	1	120.0
	97-46-2800-33	939248-8	Hanger Jam Nut	2	0.30		131-5505	31065-1	*Hinge Jaw Assembly (*Required for Jaw Sizes of 8-1/2" to 17")	1	98.0
10	131-1105	31064	Threaded Hinge Pin	4	6.00				Tong Pull Back (optional)	1	2.50
11	10-1200	24528	Hinge Pin Nut	4	1.00		10-9915	24747			



DB Manual Tong

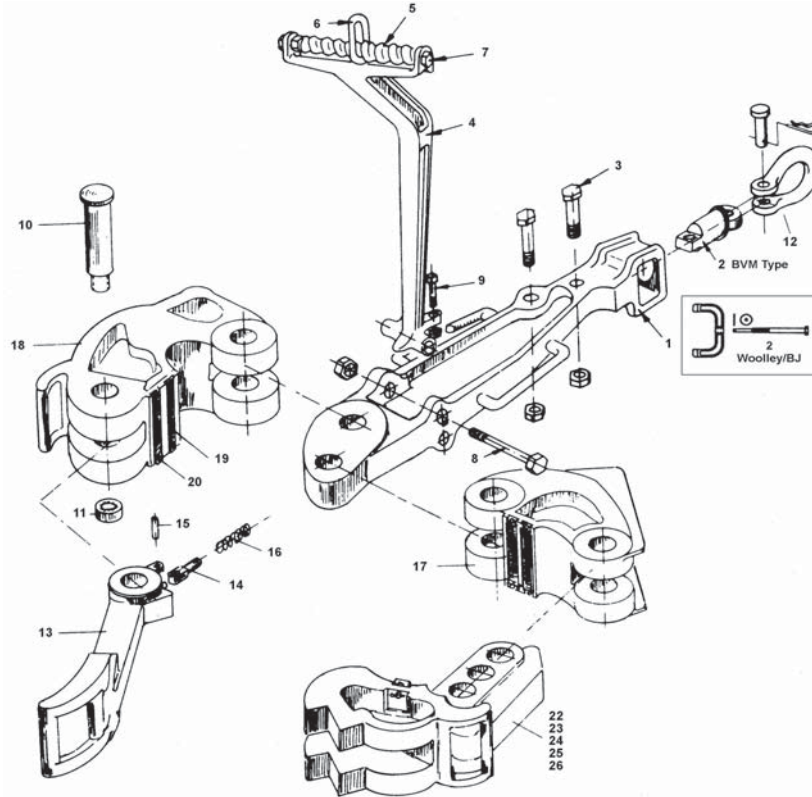

The DB Tong covers drill pipe or casing sizes from 3-1/2" to 17" OD. This Tong is made from alloy steel, heat treated and magnetic particle inspected. All steel specifications are certified. The DB Tong is rated for 65,000 FT/LBS. Torque.

CAT. #	OEM #	DESCRIPTION	QTY REQ	WT/LBS
134-1000	30111	Tong Complete with Long Lever (Less Lug Jaws)	1	412.0

Item #	Cat #	Ref #	Description	Qty	Wt/Lbs	Item #	Cat #	Ref #	Description	Qty	Wt/Lbs
	134-2100	25854-1	Lever Assembly	1	140.0	12	10-9940	N/A	Clevis Assembly (BVM - Optional)	1	2.00
1	134-2105	25854	Lever	1	135.0		134-2000	25853-1	Latch Assembly	1	37.0
2	10-1920	24529	Tong Line Retainer (BJ - Woolley)	1	1.60	13	134-2005	25853	Latch	1	35.0
3	10-2400	24249	Tong Line Ret. Bolt (BJ - Woolley)	1	1.20	14	10-7910	24526	Latch Spring Plunger	1	1.20
2	134-9700	55653	Tong Line Pin (BVM)	1	7.00	15	10-7920	24530	Latch Spring Plunger Pin	1	0.50
3	134-9705	55654	Tong Line Pin Nut & Bolt (BVM)	1	1.00	16	10-9510	24525	Latch Spring	1	0.10
	10-6800	26782	Hanger Assembly	1	56.0	17	134-5500	30065-2	Short Jaw Assembly	1	52.0
4	10-6810	26783	Hanger	1	45.0	18	134-5505	30064-2	Long Jaw Assembly	1	119.0
5	10-9700	12586	Hanger Balancing Screw	1	3.00	19	52-0171	16402-2	Tong Die, 1/2" x 1-1/4" x 5-7/8"	5	5.00
6	10-9900	12863	Suspension Ring	1	1.00	20	10-1800	17194	Die Retainer Pin	10	0.10
7	10-9760	939055-576	Hanger Balancing Screw	1	0.50		97-90-0406	939667-16	Die Retainer Cotter Pin	10	0.06
	10-9725	939484-8	Hanger Balancing Screw Nut	1	0.30	22	134-5620	30062-2	Lug Jaw, 3-1/2" to 8-1/4"	1	85.0
8	97-35-2824-33	939107-551	Hanger Bolt	1	1.00	23	134-5630	30066-2	Casing Lug Jaw 8" to 11-3/4"	1	124.0
	97-44-2800-33	940985-8	Hanger Bolt Nut	1	0.50	23	134-5670	30707-1	H.D. Lug Jaw, 8" to 11-1/4" (Optional)	1	66.0
9	97-87-2828-33	939168-133	Hanger Adjustment Screw	1	0.80	24	134-5640	30067	Lug Jaw, 11-3/4" to 14-3/8"	1	66.0
	97-46-2800-33	939248-8	Hanger Jam Nut	2	0.30	25	134-5650	30069	Lug Jaw, 16" to 17"	1	77.0
10	134-1100	25860	Threaded Hinge Pin	4	6.00	26	134-5515*	30068-3	Hinge Jaw, 11-3/4" to 17"	1	53.0
11	10-1200	24528	Hinge Pin Nut	4	1.00				*Required for Sizes Greater than 11-3/4"		



B Manual Tong

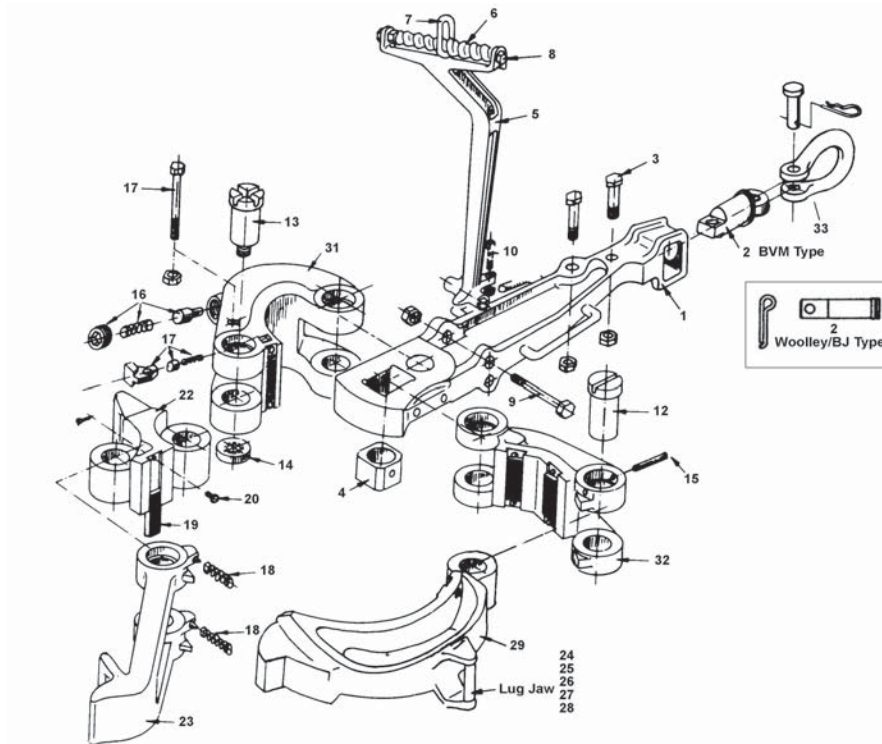

The B Tong covers drill pipe or casing sizes from 3-1/2" to 13-3/8" OD. The B Tong can also be ordered with a 36" Lever. This Tong is made from alloy steel, heat treated and magnetic particle inspected. All steel specifications are certified. The B Tong is rated for 55,000 FT/LBS. Torque.

CAT. #		OEM #		DESCRIPTION			QTY REQ		WT/LBS		
132-1000		30114		Tong Complete with Long Lever (Less Lug Jaws)			1		460.0		
Item #	Cat #	Ref #	Description	Qty	Wt/Lbs	Item #	Cat #	Ref #	Description	Qty	Wt/Lbs
1	132-2100	12434-2	Lever Assembly, 48"	1	130.0	13	132-1105	11141	Hinge Pin, Threaded	4	5.0
1	132-2110	9568-1	Lever Assembly, 36"	1	120.0	14	132-1110	11142	Hinge Pin Nut	4	0.5
1	132-2105	12434	Lever, 48"	1	124.0	15	97-90-1032	939667-77	Hinge Pin Retainer Pin	5	0.2
1	132-2115	9568	Lever, 36"	1	114.0	16	132-9910	11228	Booster Plunger Assembly	1	1.0
2	132-9800	9574	Tong Line Pin	1	6.0	17	132-9900	11139	Adjustable Stop Assembly	1	1.0
	10-9935	25468	Tong Line Pin Ret/ (BJ & Woolley)	1	1.0	18	10-9500	9561	Latch Spring	2	0.1
3	132-9700	67270	Tong Line Pin Nut & Bolt	1	1.0	19	52-0171	16402-2	Tong Die, 1/2" x 1-1/4" x 5-7/8"	5	5.0
4	132-9930	9572	Lever Pin Block	1	3.5	20	10-1800	17194	Die Retainer Pin	10	0.1
	10-6800	26782	Hanger Assembly	1	45.0		132-5615	11195-2	Latch Jaw Assembly	1	37.0
5	10-6810	26783	Hanger	1	38.0	22	10-2025	11138-1	Latch Assembly	1	31.0
6	10-9700	12586	Hanger Balancing Screw	1	3.0	23	132-2020	11138	Latch	1	27.0
7	10-9900	12863	Suspension Ring	1	1.0	24	132-5600	11765-1	Lug Jaw, 3-1/2" to 5"	1	30.0
8	10-9760	939055-576	Hanger Balancing Screw Bolt	1	0.5	25	132-5625	11196-3	Lug Jaw, 4-1/4" to 6-3/4"	1	43.0
	10-9725	939484-8	Hanger Balancing Screw Nut	1	0.5	26	132-5606	11196-2	Lug Jaw, 6-5/8" to 9"	1	61.0
9	97-35-2824-33	939107-551	Hanger Bolt	1	1.0	27	132-5608	11297-1	Lug Jaw, 9" to 10-3/4"	1	67.0
	97-44-2800-33	940985-8	Hanger Bolt Nut	1	0.3	28	132-5610	11197-1	Lug Jaw, 11-3/4"	1	68.0
10	97-87-2828-33	939168-133	Hanger Adjustment Screw	1	0.5	29	132-5624	24592-1	Lug Jaw, 13-3/8"	1	77.0
	97-46-2800-33	939248-8	Hanger Jam Nut	2	0.3	32	132-5510	11197-1	Short Jaw Assembly	1	49.0
31	132-5500	11194-1	Long Jaw Ass'y (Items 12 to 29)	1	108.0	33	10-9940	N/A	Clevis Assembly (BVM-Optional)	1	2.0
12	132-1100	11140	Hinge Pin, Removable	1	5.0		10-9915	24747	Tong Pull Back (Optional)	1	2.0



C Manual Tong

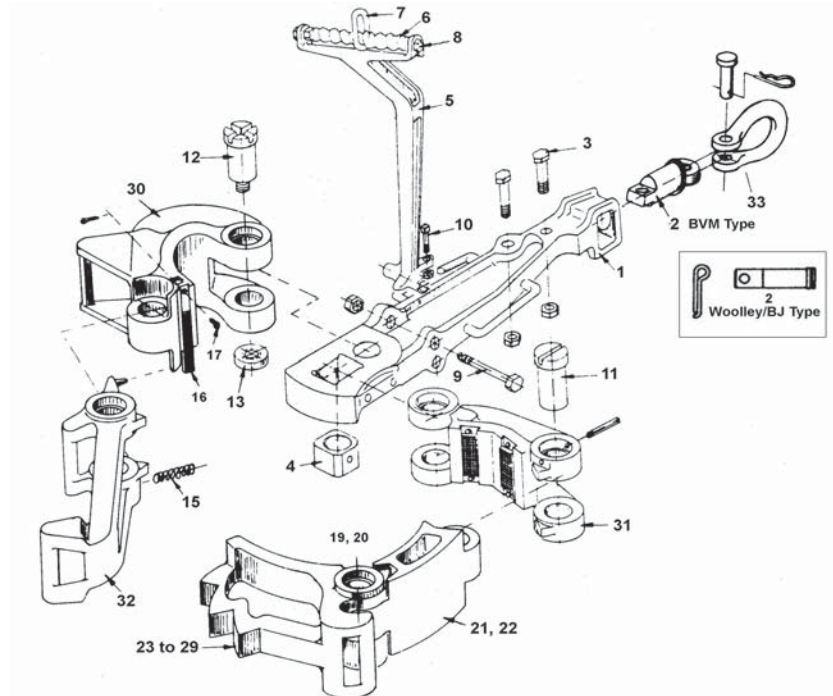

The C Tong covers drill pipe or casing sizes from 2-3/8" to 10-3/4" OD. The C Tong can also be ordered with a 30-7/8" Lever. This Tong is made from alloy steel, heat treated and magnetic particle inspected. All steel specifications are certified. The C Tong is rated for 35,000 FT/LBS. Torque.

CAT. #	OEM #	DESCRIPTION	QTY REQ	WT/LBS
133-1000	30117	Tong Complete with Long Lever (Less Lug Jaws)	1	276.0

Item #	Cat #	Ref #	Description	Qty	WtLbs	Item #	Cat #	Ref #	Description	Qty	Wt/Lbs
1	133-2105	11516-2	Lever Assembly, 40-1/2"	1	130.0	13	133-1115	11522	Hinge Pin Nut	4	0.5
	133-2100	11516	Long Lever, 40-1/2"	1	120.0	15	10-9500	9561	Latch Spring	2	0.1
	133-2110	11883	Short Lever, 30-1/2"	1	120.0	16	52-0170	16401-2	Tong Die, 1/2" x 1-1/4" x 5"	5	.75
2	133-1905	11517-1	Tong Line Pin	1	4.0	17	10-1800	17194	Die Retainer Pin	10	0.1
3	133-9700	939061-98	Tong Line Bolt	1	1.0	19	133-5620	11941-1	Latch Jaw Ass'y, 7" to 8-5/8" (#21 & #28)	1	61.0
4	133-9900	11523	Lever Pin Block	1	2.0	20	133-5626	13799-1	Latch Jaw Ass'y, 9-5/8" to 10-3/4"	1	76.0
	133-6800	13264-1	Hanger Assembly	1	44.0	21	133-5630	11942-1	Hinge Jaw Only, 7" to 8-5/8"	1	29.0
5	10-6805	13264	Hanger	1	38.0	22	133-5640	13798-1	Hinge Jaw Only, 9-5/8" to 10-3/4"	1	37.0
6	10-9700	12586	Hanger Balancing Screw	1	3.0	23	133-5600	30728-1	Lug Jaw, 2-3/8" to 3.668"	1	33.0
7	10-9900	12863	Suspension Ring	1	1.0	24	133-5605	30727-1	Lug Jaw, 2-7/8" to 4-1/4"	1	34.0
8	133-9705	30321	Hanger Balancing Screw Ass'y	1	2.3	25	133-5610	11939-4	Lug Jaw, 3-1/2" to 5-1/4"	1	31.0
	10-9760	939055-576	Hanger Balancing Screw	1	2.0	26	133-5645	11943-1	Lug Jaw, 4-1/2" to 6-1/2"	1	38.0
	10-9725	939484-8	Hanger Balancing Screw Nut	1	0.3	27	133-5615	11940-2	Lug Jaw, 5-1/4" to 7"	1	51.0
9	133-9710	30329	Hanger Bolt Assembly	1	1.5	28	133-5625	11941-2	Latch Lug Jaw, 7" to 8-5/8"	1	28.0
	97-35-2856-33	939107-515	Hanger Bolt	1	1.3	29	133-5635	13799	Latch Lug Jaw, 9-5/8" to 10-3/4"	1	39.0
	97-44-2800-33	940985-8	Hanger Bolt Nut	1	0.2	30	133-5500	11511-1	Long Jaw Ass'y (w/ #16 & #17)	1	65.0
10	97-87-2828-33	939168-133	Hanger Adjustment Screw	1	0.5	31	133-5650	11513-1	Short Jaw Ass'y (w/ #16 & #17)	1	30.0
	97-46-2800-33	939248-8	Hanger Jam Nut	2	0.3	32	133-2005	11933-2	Latch	1	29.0
11	133-1100	11520-1	Hinge Pin, Removable	1	5.0	33	10-9940	N/A	Clevis Assembly (BVM-Optional)	1	2.0
12	133-1105	11521-1	Hinge Pin, Threaded	4	5.0		10-9915	24747	Tong Pull Back (Optional)	1	2.0



Web Wilson Manual Tong

Cat. #	Ref. #	Description	Wt. Ea.	Qty. Req.	Box
AAX Tong Replacement Parts					
40-9510	4510	Tong Spring	0.25	1	A/R
40-1100	4611	Hinge Pin	4.50	4	A/R
52-0171	4731	Tong Dies, 1/2" x 1-1/4" x 5-7/8"	1.00	4	A/R
AAX Casing Tong Replacement Parts					
40-9510	4510	Tong Spring	0.25	1	A/R
40-1100	4611	Hinge Pin	4.50	4	A/R
52-0171	4731	Tong Dies, 1/2" x 1-1/4" x 5-7/8"	1.00	3	12
H Tong Replacement Parts					
145-9500	4705	Tong Spring	0.25	2	A/R
145-1100	4706	Hinge Pin	5.50	4	A/R
52-0171	4731	Tong Dies, 1/2" x 1-1/4" x 5-7/8"	1.00	4	12
B Tong Replacement Parts					
40-9510	4510	Tong Spring	0.25	2	A/R
146-1100	4411	Hinge Pin	3.25	4	A/R
52-0167	4521	Tong Dies, 3/8" x 1" x 5-3/4"	0.50	3	12
C Tong Replacement Parts					
40-9500	4210	Tong Spring	0.12	2	A/R
147-1100	4211	Hinge Pin	2.00	4	A/R
52-0165	4321	Tong Dies, 3/8" x 1" x 4-1/4"	0.38	3	12
D Tong Replacement Parts					
40-9500	4210	Tong Spring	0.12	2	A/R
148-1100	409	Hinge Pin	1.00	4	A/R
52-0165	4321	Tong Dies, 3/8" x 1" x 4-1/4"	0.38	2	12

“A” Series Center Latch Elevators TA-35, TA-65, TA-100, TA-150

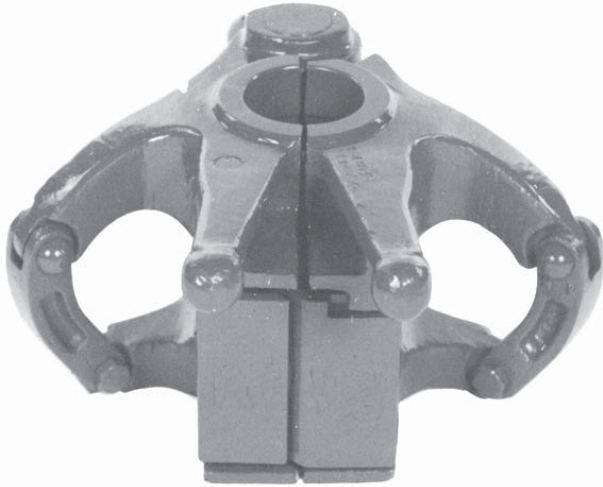

Purpose: Center Latch Collar Elevators provides superior handling of collar-type drill pipe, casing and tubing.

Special features: Proper balance for easier handling; latch and safety latch lock combination; operator safety features.

Safety features include guarded operating handles to help prevent accidents to operators and an extra handle at the rear of the elevator for easier, safer operation. All Type A elevators are equipped with a latch and safety latch lock combination.

All Elevators are made from alloy steel, heat treated and magnetic particle inspected. All steel specifications are certified.

Elevator Assemblies

Cat. #	Ref. #	Description	Wt. Ea.
TA-35 Elevator			
180-1000	32387-*	TA-35 Center Latch Elevator, 3/4" (1.050") to 2-7/8"	39-0
TA-65 Elevator			
181-1000	32385-*	TA-65 Center Latch Elevator, 1-1/4" (1.660") to 2-7/8"	65-0
181-2000	32386-*	TA-65 Center Latch Elevator, 3-1/2" to 4-1/2"	65-0
TA-100 Elevator			
182-1000	32383-*	TA-100 Center Latch Elevator, 2-3/8" to 2-7/8"	100-0
182-2000	32384-*	TA-100 Center Latch Elevator, 3-1/2" to 4-1/2"	158-0
184-1000	29960-*	SLA-100 Ton Center Latch Elevator, 5-1/2" to 8-5/8"	350-0
TA-150 Elevator			
183-1000	32754-*	TA-150 Center Latch Elevator, 5-1/2" to 8-5/8"	430-0

*Order by Part Number followed by the bore code found in the bore code chart.



"A" Series Center Latch Elevators Replacement Parts

No. Req.	Part Name	TA-35	TA-65		TA-100		TA-150	SLA-100
		3/4" to 2-7/8"	1-1/4" to 2-7/8"	3-1/2" to 4-1/2"	2-3/8" to 2-7/8"	3-1/2" to 4-1/2"	5-1/2" to 8-5/8"	5-1/2" to 8-5/8"
		Cat.# OEM # (Wt. Ea.)	Cat.# OEM # (Wt. Ea.)	Cat.# OEM # (Wt. Ea.)	Cat.# OEM # (Wt. Ea.)	Cat.# OEM # (Wt. Ea.)	Cat.# OEM # (Wt. Ea.)	Cat.# OEM # (Wt. Ea.)
1	Latch Lock Assembly (Elev. Ass'y Only)	180-2200 32484 (8.7)	10-2200 32382 (8.7)	10-2200 32382 (8.7)	10-2200 32382 (8.7)	10-2200 32382 (8.7)	183-2200 32753 (21.8)	10-2008 30708 (12.9)
1	Latch (Elev. Ass'y Only)	180-2000 32446 (5.5)	10-2000 32380 (5.5)	10-2000 32380 (5.5)	10-2000 32380 (5.5)	10-2000 32380 (5.5)	183-2300 32752-2 (15.0)	10-2009 30652 (10.0)
1	Latch Lock (Elev. Ass'y Only)	180-2201 32447 (2.8)	10-2205 32381 (2.8)	10-2205 32381 (2.8)	10-2205 32381 (2.8)	10-2205 32381 (2.8)	183-2210 32757 (5.5)	10-2010 30653 (2.0)
1	Latch Lock Pin	180-7900 36685 (.12)	10-2320 36208 (.12)	10-2320 36208 (.12)	10-2320 36208 (.12)	10-2320 36208 (.12)	183-2325 36207 (.56)	10-7903 29335 (.50)
1	Latch Lock Spring	180-9500 32483 (.18)	10-9530 32469 (.25)	10-9530 32469 (.25)	10-9530 32469 (.25)	10-9530 32469 (.25)	183-9520 32758 (.44)	10-9503 29349 (.25)
1	Hinge Pin	180-1100 32917 (2.2)	181-1100 32916 (2.2)	10-1100 32915 (2.2)	10-1100 32915 (2.2)	182-1100 32919 (3.1)	183-1100 32924 (16.0)	184-1100 29963 (3.0)
1	Latch Pin	180-7905 32424-4 (.62)	10-7907 32424-3 (.62)	10-7950 32424-2 (.62)	10-7950 32424-2 (.62)	182-2301 32424-1 (.62)	183-7900 32762 (3.12)	10-7975 29334 (.62)
1	Latch Spring	180-9505 32482 (.18)	10-9515 32470 (.18)	10-9515 32470 (.18)	10-9515 32470 (.18)	10-9515 32470 (.18)	183-9500 32760 (.44)	10-9502 29338 (.19)
2	Link Block	10-2710 23404 (1.0)	10-2715 32430 (1.0)	10-2715 32430 (1.0)	10-2715 32430 (1.0)	10-2715 32430 (1.0)	10-2705 9519 (5.25)	10-2705 9519 (5.25)
2	Link Block Pin	10-7900 23405 (.25)	10-7945 29359 (.25)	10-7945 29359 (.25)	10-7945 29359 (.25)	10-7945 29359 (.25)	10-7925 8151 (.56)	10-7925 8151 (.56)
1	Latch Lock Door Pin	-	-	-	-	-	-	10-7915 30841 (.50)
1	Latch Lock Retainer Pin	-	-	-	-	-	-	10-7960 947128-172 (.12)
1	Lockbar	180-9900 32918 (.12)	10-9910 32892 (.12)	10-9910 32892 (.12)	10-9910 32892 (.12)	182-0801 32920 (.12)	183-9920 32925 (.12)	-
2	Cotter Pin	97-90-0316 939667-19 (.06)	97-90-0316 939667-19 (.06)	97-90-0316 939667-19 (.06)	97-90-0316 939667-19 (.06)	97-90-0316 939667-19 (.06)	97-90-0316 939667-19 (.06)	97-90-0316 939667-19 (.06)
2	Link Block Bolt	10-9703 23406 (.13)	10-9735 939051-65 (.25)	10-9735 939051-65 (.25)	10-9735 939051-65 (.25)	10-9735 939051-65 (.25)	10-9775 8145 (1.19)	10-9775 8145 (1.19)
2	Link Block Nut	10-9730 939484-5 (.10)	10-9738 939484-7 (.06)	10-9738 939484-7 (.06)	10-9738 939484-7 (.06)	10-9738 939484-7 (.06)	10-9780 8150 (.13)	10-9780 8150 (.13)
2	Grease Fitting	97-85-0400 940308-1 (.06)	97-85-0400 940308-1 (.06)	97-85-0400 940308-1 (.06)	97-85-0400 940308-1 (.06)	97-85-0400 940308-1 (.06)	97-85-0400 940308-1 (.06)	97-85-0400 940308-1 (.06)
1	Latch Pin Retainer	-	-	-	-	-	183-1900 947128-222 (.50)	184-1900 29341 (.50)
1	Expansion Plug	180-9910 944048-1 (.50)	181-9900 944048-15 (.50)	10-9902 944048-16 (.50)	10-9902 944048-16 (.50)	182-9900 944048-19 (.50)	183-9900 944048-22 (.50)	-

“G” Series 18° Center Latch Elevators Type MG / RG / MGG / GG

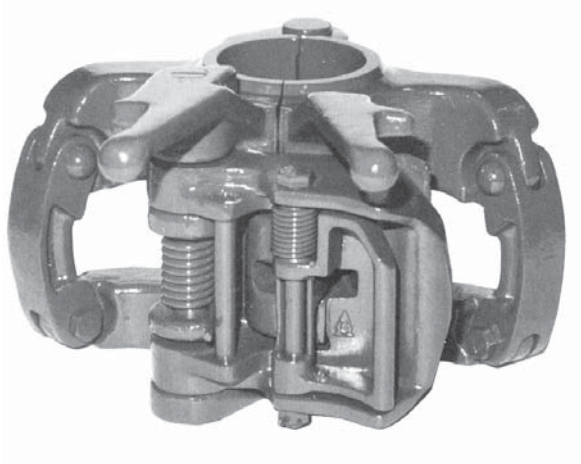

Purpose: Center Latch Collar Elevators for handling 18° external upset drill pipe and tubing. Similar in design and construction to the A-Series, except they are bored to fit the contour of 18° type drill pipe and tubing.

Special features: Proper balance for easier handling; latch and safety latch lock combination; operator safety features.

Safety features include guarded operating handles to help prevent accidents to operators and an extra handle at the rear of the elevator for easier, safer operation. All Type A elevators are equipped with a latch and safety latch lock combination.

All Elevators are made from alloy steel, heat treated and magnetic particle inspected. All steel specifications are certified.

Elevator Assemblies

Cat. #	Ref. #	Description	Wt. Ea.
MG Elevator - 100 Ton			
188-1000	30157-*	MG 100 Ton Center Latch Elevator 2-3/8", 2-7/8", 3-1/2", 4", 4-1/2" (Reg. & FH), 5", 4-1/2" (IF)	238-0
RG Elevator -150 Ton			
189-1000	30156-*	RG 150 Ton Center Latch Elevator, 2-3/8" to 3-1/2"	308-0
MGG Elevator - 175 / 250 Ton			
190-1000	13884-*	MGG 175 Ton Center Latch Elevator, 2-3/8" to 2-7/8"	365-0
190-2000	35005-*	MGG 250 Ton Center Latch Elevator, 3-1/2" to 4-1/2"	578-0
GG Elevator - 350 Ton			
191-1000	31068-*	GG 350 Ton Center Latch Elevator, 4" to 5-1/2"	715-0

*Order by Part Number followed by the bore code found in the bore code chart.



"G" Series Center Latch Elevators Replacement Parts

No. Req.	Part Name	MG	RG	MGG		GG
		2-3/8" to 5"	2-3/8", 2-7/8", 3-1/2"	2-3/8" to 2-7/8"	3-1/2" to 4-1/2"	4" to 5-1/2"
		Cat.# OEM # (Wt. Ea.)	Cat.# OEM # (Wt. Ea.)	Cat.# OEM # (Wt. Ea.)	Cat.# OEM # (Wt. Ea.)	Cat.# OEM # (Wt. Ea.)
1	Latch (Elev. Ass'y Only)	10-2003 11763 (9.25)	- 23543 (33.0)	190-2090 13151 (40.0)	- 34906 (57.0)	191-2000 31071 (50.0)
1	Latch Lock (Elev. Ass'y Only)	10-2210 11764 (3.0)	- 23729 (4.0)	10-2250 13152 (4.0)	10-2250 13152 (4.0)	10-2250 13152 (4.0)
1	Latch Cam	10-2007 11581 (.75)	- - -	- - -	- - -	- - -
2	Link Block Assembly (Female)	188-2700 26817-1 (4.75)	10-2700 9519-1 (6.06)	10-2700 9519-1 (7.0)	10-2700 9519-1 (7.0)	10-2700 9519-1 (7.0)
1	Link Block	188-2755 26817 (3.8)	10-2705 9519 (5.25)	10-2705 9519 (5.25)	10-2705 9519 (5.25)	10-2705 9519 (5.25)
1	Link Block Pin	188-2710 8031 (.31)	10-7925 8151 (.56)	10-7925 8151 (.56)	10-7925 8151 (.56)	10-7925 8151 (.56)
1	Link Block Bolt Assembly	10-9710 8145-2 (1.19)	10-9710 8145-2 (1.19)	10-9710 8145-2 (1.19)	10-9710 8145-2 (1.19)	10-9710 8145-2 (1.19)
1	Hinge Pin	188-1100 26813 (4.56)	- - -	190-1100 13888 (9.31)	190-1110 34908 (15.8)	203-1100 31072 (18.37)
1	Hinge Pin Lockbar	- - -	- - -	- - -	34910 - -	- 31074 (.50)
1	Latch Spring	10-9512 11766 (.31)	189-9500 23546 (.87)	10-9545 13155 (5.5)	190-9550 34909 (2.37)	191-9500 18416 (2.25)
1	Latch Lock Spring	- - -	10-9521 13188 (.25)	10-9521 13188 (.25)	10-9521 13188 (.25)	10-9521 13188 (.25)
1	Latch Lock Pin	10-2305 11759 (.56)	- - -	- - -	- - -	- - -
1	Latch Lock Bolt	- - -	- - -	10-9765 15101 (1.25)	10-9765 15101 (1.25)	10-9765 15101 (1.25)
1	Latch Lock Nut	- - -	- - -	10-9725 939484-8 (.18)	10-9725 939484-8 (.18)	10-9725 939484-8 (.18)
1	Latch Pin	188-2005 26814 (2.56)	- 23544 (3.9)	190-2300 13154 (6.0)	190-2010 34907 (6.75)	- 31073 (10.38)
1	Latch Pin Dowel	- - -	- - -	13191 (.12)	34911 (.25)	18608 (.12)



“G” Series Center Latch Elevators Replacement Parts

No. Req.	Part Name	MG	RG	MGG		GG
		2-3/8" to 5"	2-3/8", 2-7/8", 3-1/2"	2-3/8" to 2-7/8"	3-1/2" to 4-1/2"	4" to 5-1/2"
		Cat.# OEM # (Wt. Ea.)	Cat.# OEM # (Wt. Ea.)	Cat.# OEM # (Wt. Ea.)	Cat.# OEM # (Wt. Ea.)	Cat.# OEM # (Wt. Ea.)
1	Door Lug Pin	10-7940 12529 (.18)	- 23547 (.25)	10-7912 13190 (.31)	10-7912 13190 (.31)	10-7912 13190 (.31)
1	Door Catch Arm Pin	- - -	- - -	10-7942 12916 (.38)	10-7942 12916 (.38)	10-7942 12916 (.38)
1	Door Catch Spring	- - -	- - -	10-9500 9561 (.13)	10-9500 9561 (.13)	10-9500 9561 (.13)
1	Door Catch Arm Assembly	- - -	- - -	10-2500 13821 (2.25)	10-2500 13821 (2.25)	10-2500 13821 (2.25)
1	Cotter Pin	- - -	- - -	97-90-0410 939667-18 (.06)	- - -	- - -
1	Cotter Pin	- - -	- - -	97-90-0316 939667-19 (.06)	97-90-0316 939667-19 (.06)	97-90-0316 939667-19 (.06)
1	Grease Fitting	- - -	- - -	97-85-0400 940308-1 (.06)	97-85-0400 940308-1 (.06)	97-85-0400 940308-1 (.06)
1	Spring Stop	- - -	189-9502 23548 (.87)	10-7905 13185 (.94)	10-7905 13185 (.94)	10-7905 13185 (.94)
1	Balancing Strap Assembly (Optional)	- - -	10-2113 15320 (4.75)	10-2113 15320 (4.75)	10-2113 15320 (4.75)	10-2113 15320 (4.75)



SLX Side Door Elevators

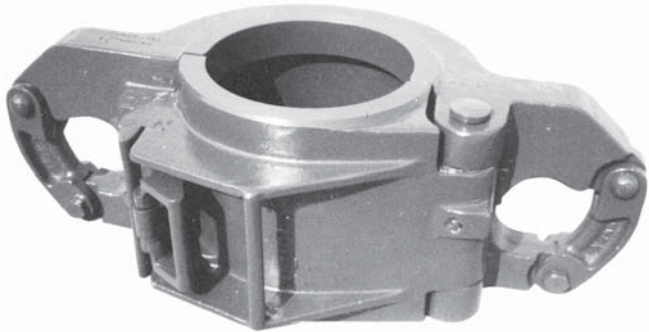

The Side Door Elevator is used for handling plain or upset collar-type drill pipe, casing and tubing. Sizes available from 4-1/2" through 24-1/2" OD, with capacity of 100, 150, 250, 350 and 500 tons.

All Elevators are made from alloy steel, heat treated and magnetic particle inspected, all steel specifications are certified.

SLX Elevator Assemblies

Cat. #	Ref. #	Description	Wt. Ea.
SLX - 100 Ton			
198-3000	33854.*	SLX-100 Ton Side Door Elevator, 4-1/2" to 5-1/2"	175-0
SLX - 150 Ton			
199-1000	31239.*	SLX-150 Ton Side Door Elevator, 6-5/8" to 8-5/8"	340-0
199-2000	33950.*	SLX-150 Ton Side Door Elevator, 9-5/8" to 10-3/4"	420-0
199-3000	33982.*	SLX-150 Ton Side Door Elevator, 11-3/4" to 13-3/8"	500-0
199-4000	34087.*	SLX-150 Ton Side Door Elevator, 16"	580-0
199-5000	33632.*	SLX-150 Ton Side Door Elevator, 18-5/8" to 20"	700-0
SLX - 250 Ton			
200-1000	43239.*	SLX-250 Ton Side Door Elevator, 6-5/8" to 8-5/8"	400-0
200-2000	43950.*	SLX-250 Ton Side Door Elevator, 9-5/8" to 10-3/4"	670-0
200-3000	43982.*	SLX-250 Ton Side Door Elevator, 11-3/4" to 13-3/8"	750-0
200-4000	43632.*	SLX-250 Ton Side Door Elevator, 16" to 20"	1000-0
200-5000	43175.*	SLX-250 Ton Side Door Elevator, 24" to 30"	1700-0
SX - 350 Ton			
201-1000	22965.*	SLX-350 Ton Side Door Elevator, 6-5/8" to 13-3/8"	1176-0
201-2000	29966.*	SLX-350 Ton Side Door Elevator, 16" to 20"	1200-0
SX - 500 Ton			
202-1000	29964.*	SLX-500 Ton Side Door Elevator, 9-5/8" to 13-3/8"	1180-0
202-2000	30729.*	SLX-500 Ton Side Door Elevator, 16" to 20"	1250-0

*Order by Part Number followed by the bore code found in the bore code chart.



Elevators Bore Code Charts

BORE CODE FOR DRILL PIPE

Drill Pipe Data		TOOL JOINT	BORE CODE	
SIZE	TYPE UPSET		SQUARE SHOULDER	18° TAPERED SHOULDER
2-3/8"	IU	API REG	109	---
	EU	WO OH SL-H90	110	116
2-7/8"	IU	API REG XH	108	117
	EU	NC31 (IF) WO OH SL-H90	101	118
3-1/2"	IU	API REG API FH	102	119
	EU	NC38 (IF) WO OH SL-H90	103	120
4"	IU	NC40 (FH) H90	104	121
	EU	NC50 (IF) WO OH	105	122
4-1/2"	IU IEU	NC45 (XH) WO OH	105	122
	EU	NC50 (IF) WO OH	106	123
5"	IEU	NC50 (XH) WO OH	106	123
5-1/2"	IEU	FH	107	124

BORE CODE FOR TUBING

TUBING SIZE	STYLE	BORE CODE	TOP BORE	BOTTOM BORE
3/4" (1.050")	PLAIN UPSET	150	1-5/32"	1-13/32"
		151	1-13/32"	1-13/32"
1" (1.315")	PLAIN UPSET	152	1-13/32"	1-19/32"
		153	1-19/32"	1-19/32"
1-1/4" (1.660")	PLAIN UPSET	154	1-3/4"	1-29/32"
		155	1-29/32"	1-29/32"
1-1/2" (1.900")	PLAIN UPSET	156	2"	2-3/16"
		157	2-3/16"	2-3/16"
2-3/8"	PLAIN UPSET	158	2-15/32"	2-23/32"
		159	2-23/32"	2-23/32"
2-7/8"	PLAIN UPSET	160	2-31/32"	3-7/32"
		161	3-7/32"	3-7/32"
3-1/2"	PLAIN UPSET	162	3-19/32"	3-27/32"
		163	3-27/32"	3-27/32"
4"	PLAIN UPSET	164	4-3/32"	4-11/32"
		165	4-11/32"	4-11/32"
4-1/2"	PLAIN UPSET	166	4-19/32"	4-29/32"
		167	4-27/32"	4-29/32"

A.P.I. CASING ELEVATOR

CASING SIZE	BORE CODE	ELEVATOR BORE
4-1/2"	129	4-19/32"
4-3/4"	130	4-27/32"
5"	131	5-3/32"
5-1/2"	132	5-19/32"
5-3/4"	133	5-27/32"
6"	134	6-3/32"
6-5/8"	135	6-23/32"
7"	136	7-3/32"
7-5/8"	137	7-3/4"
8-5/8"	139	8-3/4"
9"	140	9-1/8"
9-5/8"	141	9-3/4"
10-3/4"	142	10-7/8"
11-3/4"	143	11-29/32"
13-3/8"	144	13-17/32"
16"	145	16-3/16"
18-5/8"	146	18-25/32"
20"	147	20-7/32"
21-1/2"	148	21-21/32"
24-1/2"	149	24-21/32"

BORE CODES FOR DRILL COLLARS WITH ZIP LIFT RECESS

DRILL COLLAR O.D.	BORE CODE	DRILL COLLAR O.D.	BORE CODE
4-1/8"	177	7-1/4"	357
4-3/4"	435	7-1/2"	188
5-1/4"	179	7-3/4"	339
5-1/2"	180	8"	336
5-3/4"	181	8-1/4"	422
6"	362	8-1/2"	426
6-1/4"	337	9"	427
6-1/2"	373	9-1/2"	370
6-3/4"	387	10"	195
7"	361	11-1/4"	196



LYT-20 Ton Slip Elevator

Cat. #	Ref. #	Description	Wt. Ea.	Qty. Req.	Box
Replacement Tool Assemblies					
160-1000	28750	LYT Elevator Complete (Less Slips)	60.0	1	A/R
160-1400	28745-1	LYT Slip Body (Matched Set of 4)	12.0	1	A/R
Replacement Slip Assemblies					
160-1610	28745-7	Slip Assembly, 3/4" (1.050")	20.4	1	A/R
160-1620	28745-2	Slip Assembly, 1" (1.315")	20.4	1	A/R
160-1630	28745-3	Slip Assembly, 1-1/4" (1.660")	20.4	1	A/R
160-1640	28745-4	Slip Assembly, 1-1/2" (1.900")	17.8	1	A/R
160-1650	28745-5	Slip Assembly, 2" (2.000")	17.8	1	A/R
160-1660	28745-6	Slip Assembly, 2-1/16" (2.062")	17.8	1	A/R
Replacement Setting Plates					
160-1505	28735	Setting Plate, 3/4" (1.050")	4.0	1	A/R
160-1510	28736	Setting Plate, 1" (1.315")	3.0	1	A/R
160-1515	28784	Setting Plate, 1-1/4" (1.660")	3.0	1	A/R
160-1525	28783	Setting Plate, 1-1/2" (1.900")	3.0	1	A/R
160-1530	28737	Setting Plate, 2" (2.000")	2.2	1	A/R
160-1535	28782	Setting Plate, 2-1/16" (2.062")	2.2	1	A/R
Replacement Inserts					
160-0601	29370	Reducing Insert, 2-1/16" x 3/4" (1.050")	0.8	8	8
160-0602	28749	Reducing Insert, 2-1/16" x 1" (1.315")	0.8	8	8
160-0603	28778	Reducing Insert, 2-1/16" x 1-1/4" (1.660")	0.7	8	8
160-0604	28775	Reducing Insert, 2-1/16" x 1-1/2" (1.900")	0.4	8	8
160-0606	28772	Basic Insert, 2-1/16" x 2-1/16" (2.062")	0.4	8	8

Replacement Parts											
Cat. #	Ref. #	Description	Wt.	Qty	Bx	Cat. #	Ref. #	Description	Wt.	Qty	Bx
160-1800	28786	Insert Retainer Plate	0.1	4	A/R	160-1100	28753	Hinge Pin	.08	1	A/R
160-9700	28785	Setting Plate Screw	0.3	2	A/R	160-9900	28762-1	Link Block Assembly	1.7	2	A/R
160-9705	28787	Insert Retainer Plate Screw	0.2	2	A/R	160-9905	28762	Link Block	1.0	1	A/R
160-2005	30711	Latch and Latch Lock Ass'y	8.1	1	A/R	10-7943	28763	Link Block Pin	0.6	2	A/R
97-61-2000	939369-13	Setting Ring Screw Washer	0.1	2	A/R	160-9910	28764-1	Link Block Bolt Ass'y	0.3	1	A/R
160-2010	30644	Latch	5.8	1	A/R	160-1905	28760	Slip Retaining Pin	0.4	4	A/R
160-7910	28757	Latch Pin	0.2	1	A/R	160-9510	28761	Slip Spring	0.2	4	A/R
160-9505	32486	Latch Spring	.06	1	A/R	160-7925	941067-102	Latch Lock Door Pin	.01	1	A/R
160-2015	30645	Latch Lock	2.7	1	A/R	160-1915	947132-222	Latch Pin Retaining Pin	0.1	1	A/R
160-9500	28769	Latch Lock Spring	0.4	1	A/R	97-90-0508	939667-25	Cotter Pin	0.1	1	A/R
160-7900	28767	Latch Lock Pin	0.2	1	A/R	97-85-0400	940308-1	Grease Fitting, 1/8"	0.2	1	A/R
10-7960	947128-72	Latch Lock Pin Retainer Pin	.02	1	A/R						

MYT-40 Ton Slip Elevator

Cat. #	Ref. #	Description	Wt. Ea.	Qty. Req.	Box						
Replacement Tool Assemblies											
161-1000	29328	MYT Elevator Complete (Less Slips)	148	1	A/R						
161-1435	29343-10	Slip Body, 2-7/8" (Matched Set of 4)	31.0	1	A/R						
Replacement Slip Assemblies											
161-1610	29343-7	Slip Assembly, 1" (1.315")	50.0	1	A/R						
161-1620	29343-6	Slip Assembly, 1-1/4" (1.660")	49.5	1	A/R						
161-1630	29343-5	Slip Assembly, 1-1/2" (1.990")	49.0	1	A/R						
161-1640	29343-4	Slip Assembly, 2" (2.000")	47.8	1	A/R						
161-1650	29343-3	Slip Assembly, 2-1/16"	47.4	1	A/R						
161-1660	29343-2	Slip Assembly, 2-3/8"	46.0	1	A/R						
161-1670	29343-1	Slip Assembly, 2-7/8"	44	1	A/R						
Replacement Setting Plates											
161-1507	29354	Setting Plate, 1" (1.315")	8.0	1	A/R						
161-1505	29353	Setting Plate, 1-1/4" (1.660")	7.5	1	A/R						
161-1510	29352	Setting Plate, 1-1/2" (1.900")	7.0	1	A/R						
161-1515	29351	Setting Plate, 2" (2.00")	7.0	1	A/R						
161-1520	29350	Setting Plate, 2-1/16"	7.0	1	A/R						
161-1525	29345	Setting Plate, 2-3/8"	6.5	1	A/R						
161-1530	29348	Setting Plate, 2-7/8"	6.5	1	A/R						
Replacement Inserts											
10-0801	N/A	Reducing Insert, 2-7/8" x 3/4" (1.050")	1.1	8	8						
10-0802	29259	Reducing Insert, 2-7/8" x 1" (1.315")	1.3	8	8						
10-0803	29258	Reducing Insert, 2-7/8" x 1-1/4" (1.660")	1.3	8	8						
10-0804	29257	Reducing Insert, 2-7/8" x 1-1/2" (1.900")	1.2	8	8						
10-0806	29256	Reducing Insert, 2-7/8" x 2-1/16" (2.062")	1.1	8	8						
10-0807DM	29255DM	Reducing Insert, 2-7/8" x 2-3/8" (Directional)	1.0	8	8						
10-0808DM	24773DM	Basic Insert, 2-7/8" x 2-7/8" (Directional)	0.1	8	8						
Replacement Parts											
Cat. #	Ref. #	Description	Wt.	Qty	Bx	Cat. #	Ref. #	Description	Wt.	Qty	Bx
10-2008	30708	Latch & Latch Lock Assembly	12.1	1	A/R	161-9910	29337	Link Block	1.0	1	A/R
10-2009	30652	Latch	12.1	1	A/R	10-7945	29359	Link Block Pin	0.2	1	A/R
10-2010	30653	Latch Lock	2.0	1	A/R	161-9710	29358-1	Link Block Bolt Assembly	0.4	1	A/R
10-7903	29335	Latch Lock Pin	0.5	1	A/R	161-9700	29336	Slip Bolt	0.7	4	A/R
10-9503	29349	Latch Lock Spring	0.2	1	A/R	161-9500	29340	Slip Spring	0.4	4	A/R
10-7960	947128-172	Latch Lock Pin Retainer Pin	0.0	1	A/R	97-85-0400	940308-1	Grease Fitting, 1/8"	0.2	1	A/R
10-7975	29334	Latch Pin	4.0	1	A/R	161-1800	29344	Insert Retainer Plate	0.5	4	A/R
10-9502	29338	Latch Spring	0.5	1	A/R	161-9705	29347	Setting Plate Bolt	0.4	2	A/R
10-7915	30841	Latch Lock Door Pin	0.2	1	A/R	161-9715	29360	Insert Retainer Plate Screw	0.2	2	A/R
161-1100	29333	Hinge Pin	4.0	1	A/R	97-61-2000	939369-13	Setting Ring Screw Washer	0.1	2	A/R
161-9900	29337-1	Link Block Assembly	4.0	2	A/R						



YT-75 Ton Slip Elevator

Cat. #	Ref. #	Description	Wt. Ea.	Qty. Req.	Box						
Replacement Tool Assemblies											
162-1000	23105	YT Elevator Complete (Less Slips)	355.0	1	A/R						
162-1400	23108-2	Slip Segment, 2-7/8" (Matched Set of 4)	59.0	1	A/R						
162-1410S	23108-S	Slip Segment, 3-1/2" (Matched Set of 4)	51.0	1	A/R						
Replacement Slip Assemblies											
162-1600	23108-11	Slip Assembly, 2-7/8" x 1" (1.315")	85.8	1	A/R						
162-1610	23108-10	Slip Assembly, 2-7/8" x 1-1/4" (1.660")	85.8	1	A/R						
162-1620	23108-9	Slip Assembly, 2-7/8" x 1-1/2" (1.900")	83.6	1	A/R						
162-1630	23108-8	Slip Assembly, 2-7/8" x 2"	81.0	1	A/R						
162-1640	23108-7	Slip Assembly, 2-7/8" x 2-1/16"	81.0	1	A/R						
162-1650	23108-6	Slip Assembly, 2-7/8" x 2-3/8"	79.0	1	A/R						
162-1660	23108-4	Slip Assembly, 2-7/8" x 2-7/8"	69.0	1	A/R						
162-1670	23108-3	Slip Assembly, 3-1/2" x 2-7/8"	65.0	1	A/R						
162-1680	23108-5	Slip Assembly, 3-1/2" x 3-1/2"	62.0	1	A/R						
Replacement Setting Plates											
162-1500	29001	Setting Plate, 1"	4.80	1	A/R						
162-1505	27810	Setting Plate, 1-1/4"	4.50	1	A/R						
162-1510	27811	Setting Plate, 1-1/2"	4.25	1	A/R						
162-1515	28821	Setting Plate, 2"	4.25	1	A/R						
162-1520	27812	Setting Plate, 2-1/16"	4.25	1	A/R						
162-1525	27694	Setting Plate, 2-3/8"	4.25	1	A/R						
162-1530	27695	Setting Plate, 2-7/8"	4.25	1	A/R						
162-1535	27813	Setting Plate, 3-1/2"	4.25	1	A/R						
Replacement Inserts											
10-0801	N/A	Reducing Insert, 2-7/8" x 3/4" (1.050")	1.10	12	12						
10-0802	29259	Reducing Insert, 2-7/8" x 1" (1.315")	1.30	12	12						
10-0803	29258	Reducing Insert, 2-7/8" x 1-1/4" (1.660")	1.30	12	12						
10-0804	29257	Reducing Insert, 2-7/8" x 1-1/2" (1.900")	1.20	12	12						
10-0806	29256	Reducing Insert, 2-7/8" x 2-1/16" (2.062")	1.10	12	12						
10-0807DM	29255DM	Reducing Insert, 2-7/8" x 2-3/8" (Directional)	1.00	12	12						
10-0808DM	24773DM	Basic Insert, 2-7/8" x 2-7/8" (Directional)	0.70	12	12						
10-1308	30358	Reducing Insert, 3-1/2" x 2-7/8"	1.00	24	24						
10-1313DM	24774DM	Basic Insert, 3-1/2" x 3-1/2" (Directional)	0.50	24	24						
Replacement Parts											
Cat. #	Ref. #	Description	Wt.	Qty	Bx	Cat. #	Ref. #	Description	Wt.	Qty	Bx
162-9400	24508	Insert Spacer, 1" to 2-7/8"	0.25	4	A/R	10-7940	12529	Door Lug Pin	0.40	1	A/R
162-9406	24507	Insert Spacer, 3-1/2"	0.25	8	A/R	10-2700	9519-1	Link Block Assembly (fem.)	6.10	2	A/R
10-2015	15348	Latch	27.0	1	A/R	10-2705	9519	Link Block	5.80	1	A/R
10-7965	24182	Latch Pin	4.20	1	A/R	10-7925	8151	Link Block Pin	0.80	1	A/R
162-2010	12972	Latch Lock	3.80	1	A/R	10-9710	8145-2	Link Block Bolt Assembly	0.10	1	A/R
10-7930	13530	Latch Lock Pin	0.12	1	A/R	162-9710	27532	Insert Retainer Screw	0.10	2	A/R
10-2005	12946	Latch Cam	1.80	1	A/R	162-9715	27697	Setting Ring Retaining Screw	0.30	4	A/R
10-9505	12978	Latch Spring	0.80	1	A/R	162-9410	27696	Rubber Bushing	0.06	4	A/R
162-0900	23630-1	Guide Plate	3.00	1	A/R	162-1800	27451	Insert Retainer, 1" to 2-7/8"	0.20	4	A/R
162-9705	27533	Guide Plate Screw	0.25	2	A/R	162-1805	27530	Insert Retainer, 3-1/2"	0.12	4	A/R
162-9500	23113	Slip Spring	0.25	4	A/R	162-1810	27507	Setting Ring Retainer, 1' to 2-7/8"	0.20	2	A/R
162-9700	23115	Slip Retainer Bolt	1.20	4	A/R	162-1815	27546	Setting Ring Retainer, 3-1/2"	0.20	2	A/R
162-1100	23116	Hinge Pin	4.20	1	A/R						

YC -75 Ton Slip Elevator

Cat. #	Ref. #	Description	Wt. Ea.	Qty. Req.	Box
Replacement Tool Assemblies					
163-1000	24140	Type YC Elevator (Less Slips & Guide Plates)	455.0	1	A/R
Replacement Slips					
163-1400	24072-4	Slip Segment, 4-1/2" (Matched Set of 4)	23.0	1	A/R
193-1410	24072	Slip Segment, 5-1/2" (Matched Set of 4)	23.0	1	A/R
163-1420	24077	Slip Segment, 7" (Matched Set of 4)	19.0	1	A/R
Replacement Slip Assemblies					
163-1600	34931	Slip Assembly Complete, 4-1/2" x 3-1/2"	130.0	1	A/R
163-1610	26830	Slip Assembly Complete, 4-1/2" x 4"	120.0	1	A/R
163-1620	24072-5	Slip Assembly Complete, 4-1/2" x 4-1/2"	116.0	1	A/R
163-1630	24072-7	Slip Assembly Complete, 5-1/2" x 5"	112.0	1	A/R
163-1640	24072-2	Slip Assembly Complete, 5-1/2" x 5-1/2"	108.0	1	A/R
163-1650	24077-7	Slip Assembly Complete, 7" x 6-5/8"	108.0	1	A/R
163-1660	24077-1	Slip Assembly Complete, 7" x 7"	105.0	1	A/R
Replacement Setting Plates					
163-1500	34932	Setting Plate, 3-1/2"	8.0	1	A/R
163-1505	30209	Setting Plate, 4"	5.0	1	A/R
163-1510	30219	Setting Plate, 4-1/2"	7.0	1	A/R
163-1515	30220	Setting Plate, 5"	6.2	1	A/R
163-1520	30223	Setting Plate, 5-1/2"	6.0	1	A/R
163-1530	30226	Setting Plate, 6-5/8"	6.0	1	A/R
163-1535	30229	Setting Plate, 7"	5.2	1	A/R
Replacement Guide Plates					
163-0900	26827-1	Bottom Guide Plates, 3-1/2"	7.5	2	A/R
163-0920	26827	Bottom Guide Plates, 4"	8.5	2	A/R
163-0930	24071-4	Bottom Guide Plates, 4-1/2"	8.5	2	A/R
163-0940	24071	Bottom Guide Plates, 5"	8.0	2	A/R
163-0950	24071-1	Bottom Guide Plates, 5-1/2"	5.8	2	A/R
163-0960	24071-3	Bottom Guide Plates, 6-5/8"	5.3	2	A/R
163-0970	24071-2	Bottom Guide Plates, 7"	3.8	2	A/R
Replacement Insert Retainers					
163-1800	30214	Insert Retainer, 3-1/2", 4", 4-1/2"	2.7	4	A/R
163-1810	30221	Insert Retainer, 5"	2.2	4	A/R
163-1820	30224	Insert Retainer, 5-1/2"	2.2	4	A/R
163-1830	30227	Insert Retainer, 6-5/8"	2.2	4	A/R
163-1840	30230	Insert Retainer, 7"	2.7	4	A/R



YC-75 Ton Slip Elevator

Cat. #	Ref. #	Description	Wt. Ea.	Qty. Req.	Box
Replacement Inserts					
10-24779	24779	Reducing Insert, 4-1/2" x 3-1/2"	1.1	16	16
10-24781	24781	Reducing Insert, 4-1/2" x 4"	0.9	16	16
10-16408	16408	Basic Insert, 4-1/2" x 4-1/2"	0.5	16	16
10-24785	24785	Reducing Insert, 5-1/2" x 4-1/2"	1.1	16	16
10-24783	24783	Reducing Insert, 5-1/2" x 5"	0.9	16	16
10-16407	16407	Basic Insert, 5-1/2" x 5-1/2"	0.5	16	16
10-24748	24748	Reducing Insert, 7" x 6-5/8"	.75	24	24
10-16407	16407	Basic Insert, 7" x 7"	0.5	24	24
Slip Assembly Replacement Parts					
163-9405	24506	Insert Spacer	.25	8	A/R
163-9710	30211	Shoulder Screw	0.3	4	A/R
163-9400	30213	Rubber Bushing	0.2	4	A/R
163-1700	30216	Setting Ring Retainer	0.2	2	A/R
163-9705	941271-73	Insert Retaining Screw	.15	4	A/R
Setting Plate Assembly Replacement Parts					
163-9900	25423	Plug	.10	2	A/R
163-9905	25424	Key	.01	1	A/R
97-90-0406	939667-16	Cotter Pin	.02	2	A/R
Replacement Parts					
10-2015	15348	Latch	27	1	A/R
162-2010	12972	Latch Lock	3.0	1	A/R
10-2005	12946	Latch Cam	1.3	1	A/R
10-9505	12978	Latch Spring	.10	1	A/R
10-7965	24182	Latch Pin	5.0	1	A/R
10-7930	13530	Latch Lock Pin	0.6	1	A/R
10-7940	12529	Door Lug Pin	0.3	1	A/R
163-1100	24181	Hinge Pin	8.5	1	A/R
163-9505	24049	Slip Spring	0.4	4	A/R
163-9715	24075	Guide Plate Screw	0.3	4	A/R
10-9730	939484-5	Guide Plate Nut	.01	4	A/R
163-9700	24076	Slip Bolt	1.1	4	A/R
10-2700	9519-1	Link Block Assembly (Female)	6.3	2	A/R
10-2705	9519	Link Block	5.3	1	A/R
10-7925	8151	Link Block Pin	0.3	1	A/R
10-9710	8145-2	Link Block Bolt Assembly	0.8	1	A/R



Baash Ross UC-3 & UC-4 Casing Slips

Cat. #	Ref. #	Description	Wt. Ea.	Qty. Req.	Box
Replacement Tool Assemblies					
210-1025	7704-111	UC-3 Casing Slip, 8-5/8" (Less Inserts & Retaining Pins)	104	1	1
210-1038	7704-5033	UC-3 Casing Slip, 8-5/8" (with 7" Inserts & Retaining Pins)	130	1	1
210-1045	7704-5031	UC-3 Casing Slip, 8-5/8" (with 8-5/8" Inserts & Retaining Pins)	120	1	1
Replacement Parts					
210-1200-03	7704-A-17SF	Set, Safety Flex Handles (3 pcs)	12.6	1	A/R
210-1210	7704-A-17	Handle	5.8	3	A/R
210-1306	7704-A-16	Handle Pin	0.2	3	A/R
210-1100	7704-B-16	Hinge Pin	0.3	9	A/R
210-1800	7704-A-29	Liner Retainer Pin	0.2	A/R	A/R
Replacement Inserts					
210-4538	7704-A-112	Insert, 8-5/8" x 7"	4.5	10	10
210-4540	7704-A-113	Insert, 8-5/8" x 7-5/8"	4.0	10	10
210-4545	7704-A-22	Insert, 8-5/8" x 8-5/8"	2.0	10	10
210-5648	7704-A-125	Insert, 10-3/4" x 9"	6.5	10	10
210-5650	7704-A-9	Insert, 10-3/4" x 9-5/8"	5.0	10	10
210-5656	7704-A-8	Insert, 10-3/4" x 10-3/4"	3.0	10	10
210-6961	7704-A-39	Insert, 13-3/8" x 11-3/4"	6.2	12	12
210-6966	7704-A-92	Insert, 13-3/8" x 12 3/4"	5.7	12	12
210-6969	7704-A-38	Insert, 13-3/8" x 13-3/8"	3.5	12	12
210-7575	7704-A-45	Insert, 16" x 16"	3.5	14	14
210-7777	7704-A-99	Insert, 20" x 20"	3.5	14	14
210-8585	7704-A-100	Insert, 26" x 26"	4.2	21	21
210-8585	7704-A-100	Insert, 30" x 30"	4.2	24	24
210-8585	7704-A-100	Insert, 33" x 33"	4.2	26	26
210-8585	7704-A-100	Insert, 36" x 36"	4.2	28	28
210-8585	7704-A-100	Insert, 42" x 42"	4.2	32	32



Varco CMS-XL Casing Slips

Cat. #	Ref. #	Description	Wt. Ea.	Qty. Req.	Box
Replacement Tool Assemblies					
212-1035	5315	Casing Slip Complete (with Inserts), 6-5/8"	196.0	1	A/R
212-1038	5301	Casing Slip Complete (with Inserts), 7"	184.0	1	A/R
212-1040	5303	Casing Slip Complete (with Inserts), 7-5/8"	166.0	1	A/R
212-1045	5305	Casing Slip Complete (with Inserts), 8-5/8"	181.0	1	A/R
212-1050	5307	Casing Slip Complete (with Inserts), 9-5/8"	192.0	1	A/R
212-1056	5309	Casing Slip Complete (with Inserts), 10-3/4"	209.0	1	A/R
212-1061	5311	Casing Slip Complete (with Inserts), 11-3/4"	260.0	1	A/R
212-1069	5313	Casing Slip Complete (with Inserts), 13-3/8"	247.0	1	A/R
212-1075	5325	Casing Slip Complete (with Inserts), 16"	308.0	1	A/R
212-1076	5333	Casing Slip Complete (with Inserts), 18-5/8"	367.0	1	A/R
212-1077	5329	Casing Slip Complete (with Inserts), 20"	383.0	1	A/R
212-1078	5331	Casing Slip Complete (with Inserts), 24"	443.0	1	A/R
212-1085	5346	Casing Slip Complete (with Inserts), 26"	486.0	1	A/R
212-1090	5342	Casing Slip Complete (with Inserts), 30"	546.0	1	A/R
Replacement Parts					
36-5320	5320	Segment Right End	12.0	1	A/R
36-5322	5322	Segment Intermediate	12.0	A/R	A/R
36-5321	5321	Segment Left End	12.0	1	A/R
36-2525	2525	Hinge Pin with Cotter Pin	0.7	A/R	A/R
36-3765	3765	Front Handle	3.5	2	A/R
36-3766	3766	Center/Rear Handle	4.0	1	A/R
36-1200-03	NA	Set, Safety Flex Handles (3 pcs)	12.0	1	A/R
36-3769	3769	Handle Pin with Cotter & Washer	0.5	A/R	A/R
Replacement Button Inserts					
36-2628	2628	Button Insert for Casing Slip, 6-5/8"	0.2	144	144
36-2619	2619	Button Insert for Casing Slip, 7"	0.3	144	144
36-2630	2630	Button Insert for Casing Slip, 7-5/8"	0.1	144	144
36-2630	2630	Button Insert for Casing Slip, 8-5/8"	0.1	156	156
36-2630	2630	Button Insert for Casing Slip, 9-5/8"	0.1	168	168
36-2630	2630	Button Insert for Casing Slip, 10-3/4"	0.1	180	180
36-2627	2627	Button Insert for Casing Slip, 11-3/4"	0.2	204	204
36-2630	2630	Button Insert for Casing Slip, 13-3/8"	0.1	216	216
36-2631	2631	Button Insert for Casing Slip, 16"	0.4	252	252
36-2626	2626	Button Insert for Casing Slip, 18-5/8"	0.1	300	300
36-2631	2631	Button Insert for Casing Slip, 20"	0.4	312	312
36-2631	2631	Button Insert for Casing Slip, 24"	0.4	360	360
36-2631	2631	Button Insert for Casing Slip, 26"	0.4	396	396
36-2631	2631	Button Insert for Casing Slip, 30"	0.4	444	444



Baash Ross C-1 Drill Collar Slips

Cat. #	Ref. #	Description	Wt. Ea.	Qty. Req.	Box
Replacement Tool Assemblies					
218-1000	7638-5104	Drill Collar Slip Complete (with Liner Inserts), 3" to 4-1/2"	112.0	1	A/R
218-1010	7638-5105	Drill Collar Slip Complete (with Liner Inserts), 4-1/4" to 5-3/4"	123.0	1	A/R
218-1020	7638-5106	Drill Collar Slip Complete (with Liner Inserts), 5-1/2" to 7"	134.0	1	A/R
218-1030	7638-5107	Drill Collar Slip Complete (with Liner Inserts), 6-3/4" to 8-1/4"	119.0	1	A/R
218-1040	7638-5108	Drill Collar Slip Complete (with Liner Inserts), 8-1/2" to 10"	99.0	1	A/R
218-1050	7638-5109	Drill Collar Slip Complete (with Liner Inserts), 10" to 11-1/4"	158.0	1	A/R
218-1060	7638-5110	Drill Collar Slip Complete (with Liner Inserts), 11-1/4" to 12-3/4"	210.0	1	A/R
Body Segments					
218-1404	7638-5099-11	Right Hand Body Segment, 3" to 4-1/2"	10.8	1	A/R
218-1410	7638-5100-11	Right Hand Body Segment, 4-1/4" to 5-3/4"	9.3	1	A/R
218-1416	7638-5101-11	Right Hand Body Segment, 5-1/2" to 7"	8.3	1	A/R
218-1422	7638-5102-11	Right Hand Body Segment, 6-3/4" to 8-1/4"	7.0	1	A/R
218-1428	7638-5103-11	Right Hand Body Segment, 8-1/2" to 10"	5.8	1	A/R
218-1422	7638-5102-11	Right Hand Body Segment, 10" to 11-1/4"	7.0	1	A/R
218-1416	7638-5101-11	Right Hand Body Segment, 11-1/4" to 12-3/4"	8.3	1	A/R
218-1402	7638-5099-10	Intermediate Body Segment, 3" to 4-1/2"	10.8	6	6
218-1408	7638-5100-10	Intermediate Body Segment, 4-1/4" to 5-3/4"	9.3	8	8
218-1414	7638-5101-10	Intermediate Body Segment, 5-1/2" to 7"	8.3	10	10
218-1420	7638-5102-10	Intermediate Body Segment, 6-3/4" to 8-1/4"	7.0	10	10
218-1426	7638-5103-10	Intermediate Body Segment, 8-1/2" to 10"	5.8	10	10
218-1420	7638-5102-10	Intermediate Body Segment, 10" to 11-1/4"	7.0	15	15
218-1414	7638-5101-10	Intermediate Body Segment, 11-1/4" to 12-3/4"	8.3	17	17
218-1400	7638-5099-12	Left Hand Body Segment, 3" to 4-1/2"	10.8	1	A/R
218-1406	7638-5100-12	Left Hand Body Segment, 4-1/4" to 5-3/4"	9.3	1	A/R
218-1412	7638-5101-12	Left Hand Body Segment, 5-1/2" to 7"	8.3	1	A/R
218-1418	7638-5102-12	Left Hand Body Segment, 6-3/4" to 8-1/4"	7.0	1	A/R
218-1424	7638-5103-12	Left Hand Body Segment, 8-1/2" to 10"	5.8	1	A/R
218-1418	7638-5102-12	Left Hand Body Segment, 10" to 11-1/4"	7.0	1	A/R
218-1412	7638-5101-12	Left Hand Body Segment, 11-1/4" to 12-3/4"	8.3	1	A/R
Replacement Parts					
12-1107	7638-B-59	Hinge Pin	1.1	A/R	A/R
12-1210	7638-A-78	Slip Handle	2.5	3	A/R
12-1310	7638-E-2	Handle Pin	0.1	3	A/R
12-1215-03	NA	Set, Safety Flex Handles (3 pcs)	10.0	1	A/R
218-1800	7638-5113	Liner Keeper with Bolt & Washer	0.3	A/R	A/R
Replacement Inserts					
217-0921	7638-A-86	Renewable Liner Insert, 3" to 4-1/2"	0.7	12	12
217-1931	7638-B-81	Renewable Liner Insert, 3-3/4" to 5-1/4"	1.0	12	12
217-1527	7838-A-81	Renewable Liner Insert, 4-1/4" to 5-3/4"	0.8	12	12
12-2938	7638-A-116	Renewable Liner Insert	1.0	A/R	A/R

NOTE: Body and segments are identified as right and left hand as viewed from the back or tapered side.



Varco Drill Collar Slips

Cat. #	Ref. #	Description	Wt. Ea.	Qty.	Cat. #	Ref. #	Description	Wt. Ea.	Qty.
Replacement Assemblies									
219-1025	2572	DCS-S, 3" to 4"	112	1	221-1020	2507	DCS-L, 8" to 9-1/2"	173	1
219-1050	2573	DCS-S, 4" to 4-7/8"	103	1	221-1030	2530	DCS-L, 8-1/2" to 10"	185	1
220-1025	2552	DCS-R, 4-1/2" to 6"	120	1	221-1040	2508	DCS-L, 9-1/4" to 11-1/4"	198	1
220-1050	2550	DCS-R, 5-1/2" to 7"	112	1	221-1050	2534	DCS-L, 11" to 12-3/4"	213	1
221-1000	2501	DCS-L, 5-1/2" to 7"	163	1	221-1060	2536	DCS-L, 12" to 14"	207	1
221-1010	2503	DCS-L, 6-3/4" to 8-1/4"	154	1					
Replacement Parts									
36-2568	2568	Segment-Right End, DCS-S	11.0	1	36-2511	2511	Segment-Left End, DCS-L	12.0	1
36-2570	2570	Segment-Intermediate, DCS-S	11.0	A/R	36-2525	2525	Hinge Pin with Cotter Pin	0.70	6
36-2569	2569	Segment-Left End, DCS-S	11.0	1	36-3765	3765	Front Handle	3.50	2
36-2554	2554	Segment-Right End, DCS-R	11.0	1	36-3766	3766	Center/Rear Handle	4.00	1
36-2556	2556	Segment-Intermediate, DCS-R	11.0	A/R	36-3769	3769	Handle Pin w/ Cotter & Washer	0.50	3
36-2555	2555	Segment-Left End, DCS-R	11.0	1	97-90-0608	71936	Insert Cotter for DCS-S, DCS-R	0.01	A/R
36-2510	2510	Segment-Right End, DCS-L	12.0	1	97-1335	3748	Ret. Screw w/Washer for DCS-L	0.20	A/R
36-2512	2512	Segment-Intermediate, DCS-L	12.0	A/R	36-1200-03	NA	Set, Safety Flex Handles (3 pcs)	12.0	1
Button Inserts									
36-2628	2628	DCS-S Circular Button, 3" to 4"	0.20	49	36-2630	2630	DCS-L Circular Button, 8" to 9-1/2"	0.10	96
36-2620	2620	DCS-S Circular Button, 4" to 4-7/8"	0.10	49	36-2627	2627	DCS-L Circular Button, 8-1/2" to 10"	0.20	104
36-2628	2628	DCS-R Circular Button, 4-1/2" to 6"	0.20	63	36-2630	2630	DCS-L Circular Button, 9-1/4" to 11-1/4"	0.10	112
36-2620	2620	DCS-R Circular Button, 5-1/2" to 7"	0.10	63	36-2625	2625	DCS-L Circular Button, 11" to 12-3/4"	0.20	136
36-2513	2513	DCS-L Circular Button, 5-1/2" to 7"	0.20	88	36-2630	2630	DCS-L Circular Button, 12" to 14"	0.20	136
36-2630	2630	DCS-L Circular Button, 6-3/4" to 8-1/4"	0.10	88					

Woolley A Drill Collar Slips Replacement Inserts & Parts

Drill Collar Size Range				3" to 4-1/4"	3-1/4" to 4-3/4"	4-1/4" to 5-3/4"	5-1/2" to 7"	6-3/4" to 8-1/4"	8-1/4" to 10"	10" to 11-3/4"
Cat. #	Ref. #	Description	Wt.	Qty.	Qty.	Qty.	Qty.	Qty.	Qty.	Qty.
222-2938	797-000-0000	Renewable Insert	0.25	21	24	27	30	33	36	39
222-1100	707-000-0100	Hinge Pin	0.50	6	7	8	9	10	11	12
222-1200	707-000-0200	Handle	2.00	3	3	3	3	3	3	3
222-1230-03	707-000-0207	Set, Safety Flex Handles	9.00	1	1	1	1	1	1	1
222-1300	707-000-0300	Handle Pin	0.25	3	3	3	3	3	3	3
	117-005-0400	Handle/Hinge Pin Cotter	0.01	9	10	11	12	13	14	15
222-1800	707-000-0600	Insert Retainer Pin	0.25	7	8	9	10	11	-	-
222-1805	707-000-0700	Insert Retainer Pin	0.25	-	-	-	-	-	12	15
	117-005-0200	Ret. Pin Cotter	0.25	7	8	9	10	11	12	15

Baash Ross Type C Safety Clamps

Clamp with Wrench			Clamp & Box with Wrench			Description
Cat. #	Ref. #	Wt.	Cat. #	Ref. #	Wt.	
Type CR (Single Screw)						
225-1007	7624-5055	50	225-1007B	7624-5007	100	Type C 7 Link CR, 3-3/4" to 4-5/8"
225-1008	7624-5056	56	225-1008B	7624-5008	106	Type C 8 Link CR, 4-1/2" to 5-5/8"
225-1009	7624-5057	61	225-1009B	7624-5009	111	Type C 9 Link CR, 5-1/2" to 6-5/8"
225-1010	7624-5058	66	225-1010B	7624-5010	116	Type C 10 Link CR, 6-1/2" to 7-5/8"
225-1011	7624-5059	72	225-1011B	7624-5011	122	Type C 11 Link CR, 7-1/2" to 8-5/8"
225-1012	7624-5060	78	225-1012B	7624-5012	128	Type C 12 Link CR, 8-1/2" to 9-5/8"
225-1013	7624-5061	84	225-1013B	7624-5013	134	Type C 13 Link CR, 9-1/2" to 10-5/8"
Type CL (Single Screw)						
225-1014	7624-5062	90	225-1014B	7624-5014	150	Type C 14 Link CL, 10-1/2" to 11-5/8"
225-1015	7624-5063	96	225-1015B	7624-5015	156	Type C 15 Link CL, 11-1/2" to 12-5/8"
225-1016	7624-5064	102	225-1016B	7624-5016	152	Type C 16 Link CL, 12-1/2" to 13-5/8"
225-1017	7624-5065	108	225-1017B	7624-5017	158	Type C 17 Link CL, 13-1/2" to 14-5/8"
225-1018-1	7624-5066	114	225-1018-1B	7624-5018	164	Type C 18 Link CL, 14-1/2" to 15-5/8"
Type CXL (Double Screw)						
225-1018-2	7624-5084	120	225-1018-2B	7624-5029	170	Type C 18 Link CXL, 15-1/2" to 17"
225-1019	7624-5085	126	225-1019B	7624-5030	176	Type C 19 Link CXL, 16-1/2" to 18"
225-1020	7624-5086	132	225-1020B	7624-5031	182	Type C 20 Link CXL, 17-1/2" to 19"
225-1021	7624-5087	138	225-1021B	7624-5032	188	Type C 21 Link CXL, 18-1/2" to 20"
225-1022	7624-5089	146	225-1022B	7624-5033	196	Type C 22 Link CXL, 19-1/2" to 22"

Other Sizes Available on Request.

Cat. #	Ref. #	Description	Wt. Ea.	Qty. Req.	Box
Replacement Parts & Inserts					
225-1410	7624-A-24	Pivot End Link	3.5	1	A/R
12-9910	7624-A-5000	Pivot Block	1.5	1	A/R
12-7910	7624-D-5	Pivot Pin	0.5	2	A/R
225-1415	7624-A-3	Screw End Link	4.5	1	A/R
12-7915	7624-F-5	Pin with Chain	1.2	1	A/R
12-9710	7624-A-5	Screw for Screw End Link	4.0	1	A/R
12-9720	7624-B-5	Nut for Screw End Link	1.5	1	A/R
12-9900	7624-A-25	Wrench for Nut on Screw End Link	4.0	1	A/R
225-1400	7624-A-7	Intermediate Link Assembly w/ Link Pin	5.0	A/R	A/R
225-5000	7624-A-4	Insert with Spring & Cotter	0.7	A/R	A/R
225-9510	7624-E-5	Insert Spring	0.1	A/R	A/R
97-90-0808	900620-65	Cotter Pin for Inserts	0.1	A/R	A/R
12-7905	7624-C-5	Link Pin	0.7	A/R	A/R
97-90-0612	900620-36	Cotter Pin for Link Pins	0.2	A/R	A/R
225-1405	7624-A-1	Intermediate Link (Less Insert)	3.7	A/R	A/R
225-1200	7624-5135	Handle Kit	4.0	A/R	A/R
36-3331	7624-A-97	Storage Box, 6-1/2" x 24" x 17"	50.0	1	A/R



Baash Ross Type T Safety Clamps

Cat. #	Ref. #	Description	Wt. Ea.	Qty. Req.	Box
Safety Clamp Assemblies					
226-1000	7624-5103	Clamp Ass'y T' 4 Link, 1-1/8" to 2"	35	1	A/R
226-1000B	7624-5044	Clamp Ass'y T' 4 Link, 1-1/8" to 2" with Box	84	1	A/R
226-1005	7624-5104	Clamp Ass'y T' 5 Link, 2-1/8" to 3-1/4"	40	1	A/R
226-1005B	7624-5045	Clamp Ass'y T' 5 Link, 2-1/8" to 3-1/4" with Box	88	1	A/R
226-1010	7624-5105	Clamp Ass'y T' 6 Link, 3-1/4" to 4-1/2"	44	1	A/R
226-1010B	7624-5046	Clamp Ass'y T' 6 Link, 3-1/4" to 4-1/2" with Box	92	1	A/R
Replacement Parts					
226-1405	7624-A-19	Pivot End Link	3.5	1	A/R
12-9910	7624-A-5000	Pivot Block	1.5	1	A/R
12-7910	7624-D-5	Pivot Pin	0.2	2	A/R
226-1410	7624-A-20	Screw End Link	4.5	1	A/R
12-7915	7624-F-5	Pin with Chain	1.2	1	A/R
12-9710	7624-A-5	Screw	4.0	1	A/R
12-9720	7624-B-5	Nut	1.5	1	A/R
12-9900	7624-A-25	Wrench	4.0	1	A/R
226-1411	7624-B-7	Intermediate Link Assembly	4.2	A/R	A/R
226-5000	7624-A-21	Insert with Spring & Cotter	0.5	A/R	A/R
226-9515	7624-B-21	Insert Spring	0.1	A/R	A/R
97-90-0808	900620-65	Cotter Pin for Inserts	0.1	A/R	A/R
12-7905	7624-C-5	Link Pin	0.7	A/R	A/R
97-90-0612	900620-36	Cotter Pin for Link Pins	0.2	A/R	A/R
226-1400	7624-A-18	Intermediate Link (Less Insert)	3.5	A/R	A/R
226-1205	7624-5138	Handle Kit	3.5	A/R	A/R



Varco MP Safety Clamps

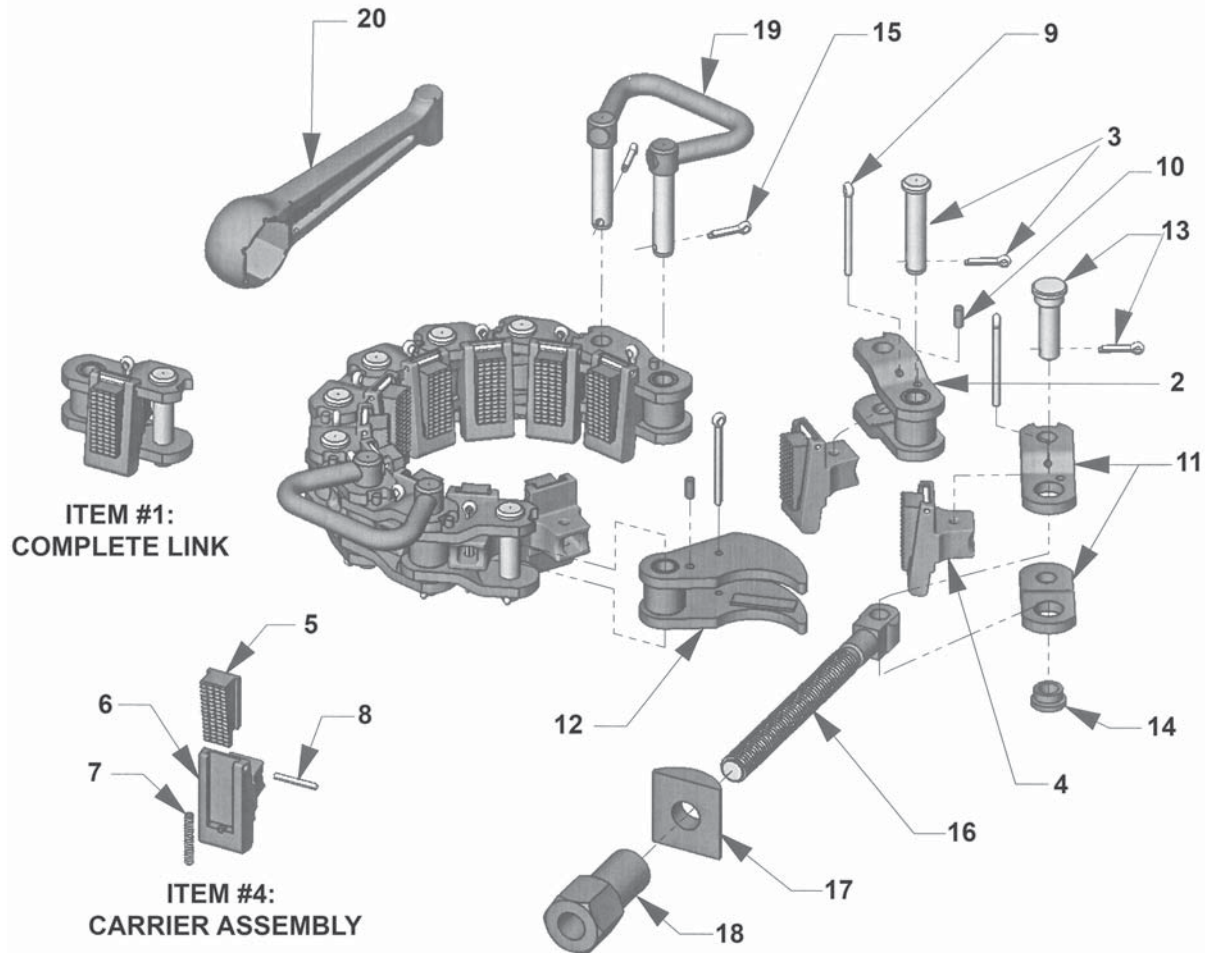

Cat. #	Ref. #	Description	# Lks	Dies	Wt.	Cat. #	Ref. #	Description	Lks	Dies	Wt.
MP-S Safety Clamps						MP-L Safety Clamps					
227-1000	33030	MP-S Clamp, 2-7/8" - 4-1/8"	7	8	125	230-1000	33021	MP-L Clamp, 15-7/8" - 17"	17	18	215
227-1010	33031	MP-S Clamp, 4" - 5"	8	9	133	230-1010	33022	MP-L Clamp, 17" - 18-1/2"	18	19	223
MP-R Safety Clamps						MP-XL Safety Clamps					
228-1000	33011	MP-R Clamp, 4-1/2" - 5-5/8"	7	8	123	231-1000	33024	MP-XL Clamp, 19-3/8" - 20-3/8"	19	20	280
228-1010	33012	MP-R Clamp, 5-1/2" - 7"	8	9	131	231-1010	33025	MP-XL Clamp, 20-3/8" - 21-1/2"	20	21	288
228-1020	33013	MP-R Clamp, 6-3/4" - 8-1/4"	9	10	139	231-1020	33032	MP-XL Clamp, 21" - 22-5/8"	21	22	296
228-1030	33014	MP-R Clamp, 8" - 9-1/4"	10	11	147	231-1030	33033	MP-XL Clamp, 22-5/8" - 23-3/4"	22	23	304
228-1040	33015	MP-R Clamp, 9-1/4" - 10-1/2"	11	12	155	231-1040	33034	MP-XL Clamp, 23-3/4" - 24-7/8"	23	24	312
MP-M Safety Clamps						231-1050	33035	MP-XL Clamp, 24-7/8" - 26"	24	25	320
229-1000	33016	MP-M Clamp, 10-1/2" - 11-1/2"	12	13	163	231-1060	33036	MP-XL Clamp, 26" - 27-1/8"	25	26	328
229-1010	33017	MP-M Clamp, 11-1/2" - 12-1/2"	13	14	171	231-1070	33039	MP-XL Clamp, 29-3/8" - 30-1/2"	28	29	336
229-1020	33018	MP-M Clamp, 12-1/2" - 13-5/8"	14	15	179	231-1080	33044	MP-XL Clamp, 35" - 36-1/8"	33	34	354
229-1030	33019	MP-M Clamp, 13-5/8" - 14-3/4"	15	16	187						
229-1040	33020	MP-M Clamp, 14-3/4" - 15-7/8"	16	17	195						



MP Safety Clamp Parts

Item #	Description	MP-S		MP-R		MP-M		MP-L		MP-XL	
		Cat. # Ref. #	# Req. (Wt.)	Cat. # Ref. #	# Req. (Wt.)	Cat. # Ref. #	# Req. (Wt.)	Cat. # Ref. #	# Req. (Wt.)	Cat. # Ref. #	# Req. (Wt.)
1	Complete Link Ass'y (Includes #2 thru #4)	36-3335 3335	AR (9.0)	36-3319 3319	1 (8.8)	36-3319 3319	1 (8.8)	36-3319 3319	1 (8.8)	36-3319 3319	1 (8.8)
2	Link	36-3306 3306	1 (4.5)	36-3306 3306	1 (4.5)	36-3306 3306	1 (4.5)	36-3306 3306	1 (4.5)	36-3306 3306	1 (4.5)
3	Intermediate Pin (w/Cotter)	36-3307 3307	1 (.80)	36-3307 3307	1 (.80)	36-3307 3307	1 (.80)	36-3307 3307	1 (.80)	36-3307 3307	1 (.80)
4	Carrier Assembly (Includes #5 thru #9)	36-3325 3325	1 (3.0)	36-3324 3324	1 (2.5)	36-3324 3324	1 (2.5)	36-3324 3324	1 (2.5)	36-3324 3324	1 (2.5)
5	Die Grip	36-3333 3333	1 (1.5)	36-3310 3310	1 (.88)	36-3310 3310	1 (.88)	36-3310 3310	1 (.88)	36-3310 3310	1 (.88)
6	Carrier Die	36-3309 3309	1 (3.0)	36-3309 3309	1 (3.0)	36-3309 3309	1 (3.0)	36-3309 3309	1 (3.0)	36-3309 3309	1 (3.0)
7	Spring	36-3311 3311	1 (.02)	36-3311 3311	1 (.02)	36-3311 3311	1 (.02)	36-3311 3311	1 (.02)	36-3311 3311	1 (.02)
8	Roll Pin	97-82-0818 51604-18	1 (.10)	97-82-0818 51604-18	1 (.10)	97-82-0818 51604-18	1 (.10)	97-82-0818 51604-18	1 (.10)	97-82-0818 51604-18	1 (.10)
9	Cotter Pin for Carrier	97-90-1030 51405-28	1 (.09)	97-90-1030 51405-28	1 (.09)	97-90-1030 51405-28	1 (.09)	97-90-1030 51405-28	1 (.09)	97-90-1030 51405-28	1 (.09)
10	Dowell Pin, 3/8" x 7/8"	36-9700 50060-07-0	1 (.03)	36-9700 50060-07-0	1 (.03)	36-9700 50060-07-0	1 (.03)	36-9700 50060-07-0	1 (.03)	36-9700 50060-07-0	1 (.03)
11	Link Side Bars, Set of 2	36-3316 3316	1 (3.0)	36-3316 3316	1 (3.0)	36-3316 3316	1 (3.0)	36-3316 3316	1 (3.0)	36-3316 3316	1 (3.0)
12	Latch Link	36-3304 3304	1 (5.8)	36-3304 3304	1 (5.8)	36-3304 3304	1 (5.8)	36-3304 3304	1 (5.8)	36-3321 3321	1 (10)
13	Screw Pin (w/Cotter)	36-3308 3308	1 (.80)	36-3308 3308	1 (.80)	36-3308 3308	1 (.80)	36-3308 3308	1 (.80)	36-3308 3308	1 (.80)
14	Screw Pin Bushing	36-3315 3315	1 (.40)	36-3315 3315	1 (.40)	36-3315 3315	1 (.40)	36-3315 3315	1 (.40)	36-3315 3315	1 (.40)
15	Cotter Pin for Link Pin	97-90-1010 51405-10	AR (.02)	97-90-1010 51405-10	AR (.02)	97-90-1010 51405-10	AR (.02)	97-90-1010 51405-10	AR (.02)	97-90-1010 51405-10	AR (.02)
16	Screw	36-3302 3302	1 (4.5)	36-3302 3302	1 (4.5)	36-3302 3302	1 (4.5)	36-3302 3302	1 (4.5)	36-3302 3302	1 (4.5)
17	Thrust Washer	36-2714 2714	1 (1.2)	36-2714 2714	1 (1.2)	36-2714 2714	1 (1.2)	36-2714 2714	1 (1.2)	36-2714 2714	1 (1.2)
18	Nut	36-3303 3303	1 (3.5)	36-3303 3303	1 (3.5)	36-3303 3303	1 (3.5)	36-3303 3303	1 (3.5)	36-3303 3303	1 (3.5)
19	Handle	36-3305 3305	2 (4.2)	36-3305 3305	2 (4.2)	36-3305 3305	2 (4.2)	36-3305 3305	4 (4.2)	36-3305 3305	4 (4.2)
20	Wrench	36-3320 3320	1 (4.9)	36-3320 3320	1 (4.9)	36-3320 3320	1 (4.9)	36-3320 3320	1 (4.9)	36-3320 3320	1 (4.9)
21	Box (Optional) (Not Shown)	36-3331 3331	1 (50)	36-3331 3331	1 (50)	36-3331 3331	1 (50)	36-3331 3331	1 (50)	36-3334 3334	1 (84)
22	Holdown Lug (Optional) (Not Shown)	36-3316 3316	2 (5.8)	36-3316 3316	2 (5.8)	36-3316 3316	2 (5.8)	36-3316 3316	4 (5.8)	36-3316 3316	4 (5.8)
23	Lifting Eye (Not Shown)	36-3317 3317	2 (4.8)	36-3317 3317	2 (4.8)	36-3317 3317	2 (4.8)	36-3317 3317	4 (4.8)	36-3317 3317	4 (4.8)



BJ 50 Ton Slip Spiders

Cat. #	Ref. #	Description	Wt. Ea.	Qty. Req.	Box
Replacement Slip Assemblies					
250-1608	29693	Slip Body Assembly with 2-7/8" Inserts	55.0	1	A/R
Replacement Parts					
250-3925	943485-17	Air Cylinder	6.0	1	A/R
250-8400	N/A	Repair Kit for Air Cylinder	1.5	1	A/R
250-3900	N/A	Cross Pin for Shaft	0.1	1	A/R
250-3905	1043	Air Cylinder Piston Head	0.1	1	A/R
250-3910	N/A	Barrel	2.0	1	A/R
250-3915	1042	Air Cylinder Piston Head	0.2	1	A/R
250-6400	N/A	Stainless Steel Shaft	2.0	1	A/R
250-2100	29677	Lifting Arm-Left	1.0	1	A/R
250-2105	29678	Lifting Arm-Right	1.0	1	A/R
250-9700	940585-66	Shoulder Bolt, Arm Pivot Pin	0.7	2	A/R
250-1100	36179	Hinge Pin	1.5	2	A/R
250-9500	30149	Hinge Pin Spring	0.2	2	A/R
Replacement Slip Inserts, 2-7/8"					
10-0802	29259	Reducing Insert, 2-7/8" x 1" (1.315")	1.3	6	6
10-0804	29257	Reducing Insert, 2-7/8" x 1-1/2" (1.900")	1.2	6	6
10-0803	29258	Reducing Insert, 2-7/8" x 1-1/4" (1.660")	1.3	6	6
10-0806	29256	Reducing Insert, 2-7/8" x 2-1/16" (2.062")	1.1	6	6
10-0807DM	29255	Reducing Insert, 2-7/8" x 2-3/8" (Directional Machine)	1.0	6	6
10-0808DM	24773	Basic Insert, 2-7/8" x 2-7/8" (Directional Machine)	0.7	6	6
Replacement Slip Inserts, 3-1/2"					
10-1308	30358	Reducing Insert, 3-1/2" x 2-7/8"	1.0	12	12
10-1313	24774	Basic Insert, 3-1/2" x 3-1/2"	0.5	12	12
10-1313DM	24774DM	Basic Insert, 3-1/2" x 3-1/2" (Directional Machine)	0.5	12	24

BJ 100 Ton Slip Spiders

Cat. #	Ref. #	Description	Wt. Ea.	Qty. Req.	Box
Replacement Slip Inserts, 2-7/8"					
10-0802	29259	Reducing Insert, 2-7/8" x 1" (1.315")	1.3	9	12
10-0804	29257	Reducing Insert, 2-7/8" x 1-1/2" (1.900")	1.2	9	12
10-0803	29258	Reducing Insert, 2-7/8" x 1-1/4" (1.660")	1.3	9	12
10-0806	29256	Reducing Insert, 2-7/8" x 2-1/16" (2.062")	1.1	9	12
10-0807DM	29255	Reducing Insert, 2-7/8" x 2-3/8" (Directional Machine)	1.0	9	12
10-0808DM	24773	Basic Insert, 2-7/8" x 2-7/8" (Directional Machine)	0.7	9	12
Replacement Slip Inserts, 3-1/2"					
10-1308	30358	Reducing Insert, 3-1/2" x 2-7/8"	1.0	18	18
10-1313	24774	Basic Insert, 3-1/2" x 3-1/2"	0.5	18	18



Model B Cavins Tubing Spiders

Cat. #	Ref. #	Description	Wt. Ea.	Qty. Req.	Box
Model B Full Circle Replacement Inserts, 2-7/8" Body					
260-0803	TB-651-1-1/4	FCI for Cavins Model B, 2-7/8" x 1-1/4"	14.4	4	4
260-0804	TB-651-1-1/2	FCI for Cavins Model B, 2-7/8" x 1-1/2"	13.8	4	4
260-0806	TB-651-2-1/16	FCI for Cavins Model B, 2-7/8" x 2-1/16"	3.20	4	4
260-0807	TB-651-2-3/8	FCI for Cavins Model B, 2-7/8" x 2-3/8"	2.30	4	4
260-0808	TB-650-2-7/8	FCI for Cavins Model B, 2-7/8" x 2-7/8"	1.60	4	4
Model B Replacement Chevron Inserts (Set of 8 replaces 6 Left & 6 Right)					
260-5007	TB-160-2-3/8	Chevron Insert for Cavins Model B, 2-3/8"	0.20	8	8
260-5008	TB-160-2-7/8	Chevron Insert for Cavins Model B, 2-7/8"	0.20	8	8
Model B & C Replacement Button Inserts					
14-5107	TB-156-2-3/8	Button Insert for Cavins, 2-3/8"	0.20	24 (B) / 28 (C)	24
14-5108	TB-156-2-7/8	Button Insert for Cavins, 2-7/8"	0.20	24 (B) / 28 (C)	24
14-5113	TB-156-3-1/2	Button Insert for Cavins, 3-1/2"	0.20	24 (B) / 28 (C)	24
14-5121	TC-156-4-1/2	Button Insert for Cavins, 4-1/2"	0.20	56 (C)	56

Model C Cavins Tubin Spiders

Model C Tubing Spider & Slip Body Assemblies					
261-1000	TC100-C	Spider Model C 82.5 Ton, 1" to 5-1/2" (Less Slip Body & Inserts)	457	1	1
261-1000HD	TC-100-CHD	Spider Model C-HD 125 Ton, 1" to 5-1/2" (Less Slip Body & Inserts)	485	1	1
261-1013	TC101-C	Spider Model C 82.5 Ton, with 3-1/2" Slip Body (Less Inserts)	460	1	1
261-1013HD	TC101-CHD	Spider Model C-HD 125 Ton, with 3-1/2" Slip Body (Less Inserts)	505	1	1
261-1613	TC600	Slip Body Ass'y Model C, 3-1/2" (Less Inserts)	45.0	1	1
261-1621	N/A	Slip Body Ass'y Model C, 4-1/2" (Less Inserts)	45.0	1	1
14-1800	TC601	Insert Retainer Pin	0.30	4	A/R
14-9700	N/A	Bolt & Nylock Nut Kit Model B & C, 5/8" x 3-3/4"	0.50	1	A/R
Model C' Replacement Inserts, 3-1/2" Slip Body					
261-1303	N/A	FCI for Cavins Model C, 3-1/2" x 1-1/4"	5.2	4	4
261-1304	N/A	FCI for Cavins Model C, 3-1/2" x 1-1/2"	5.2	4	4
261-1306	N/A	FCI for Cavins Model C, 3-1/2" x 2-1/16"	5.0	4	4
261-1307	TC-651-2-3/8	FCI for Cavins Model C, 3-1/2" x 2-3/8"	4.0	4	4
261-1308	TC-651-2-7/8	FCI for Cavins Model C, 3-1/2" x 2-7/8"	3.5	4	4
261-1313	TC-650-3-1/2	FCI for Cavins Model C, 3-1/2" x 3-1/2"	2.2	4	4
Model C' Replacement Inserts, 4-1/2" Slip Body					
261-2113	TC-651-4 1/2 x 3 1/2	FCI for Cavins Model C 4-1/2" x 3-1/2"	5.50	4	4
261-2117	TC-651-4 1/2 x 4"	FCI for Cavins Model C 4-1/2" x 4"	4.50	4	4
261-2121	TC-651-4 1/2 x 4-1/2"	FCI for Cavins Model C 4-1/2"	3.00	4	4



Cavins Tubing Spiders Models C Replacement Inserts

Cat. #	Ref. #	Description	Wt. Ea.	Qty. Req.	Box
Model C' Replacement Inserts for 4-1/2" Slip Body					
261-2113	TC-651-3-1/2	FCI for Cavins Model C, 4-1/2" x 3-1/2"	5.3	4	4
261-2117	TC-651-4	FCI for Cavins Model C, 4-1/2" x 4"	4.2	4	4
261-2121	TC-650-4-1/2	FCI for Cavins Model C, 4-1/2" x 4-1/2"	3.0	4	4

Cavins Tubing Spiders Replacement Parts

No. Req.	Part Name	Model B			Model C			Model C-HD		
		Cat. #	OEM #	Wt.	Cat. #	OEM #	Wt.	Cat. #	OEM #	Wt.
1	Link Assembly	260-4995	TB103	5.00	261-4995	TC103	5.00	261-4995	TC103	5.00
1	Link		TB103-1			TC103-1			TC103-1	
2	Grease Fitting	260-9890	TB123	0.10	260-9890	TB123	0.10	260-9890	TB123	0.10
2	Link Bushing	14-9405	TB125	0.10	14-9405	TB125	0.10	14-9405	TB125	0.10
1	Left Hand Shaft	260-6405	TB104	7.00	261-6405	TC104	7.00	261-6405	TC104	7.00
1	Right Hand Shaft	260-6410	TB105	7.00	261-6410	TC105	7.00	261-6410	TC105	7.00
2	Lift Arm	260-7106	TB106	3.00	261-7106	TC106	3.00	261-7106	TC106	3.00
2	Set Screw	260-9750	TB118	0.10	260-9750	TB118	0.10	260-9750	TB118	0.10
1	Lift Arm Bolt	260-9760-1	TB116	0.50	260-9760-1	TB116	0.50	260-9760-1	TB116	0.50
1	Lift Arm Nut	260-9760-2	TB117	0.20	260-9760-2	TB117	0.20	260-9760-2	TB117	0.20
1	Air Cylinder Guard		TB108			TC108			TC108	
5	Guard Screw		TB113			TB113			TB113	
1	Gate Bolt	260-9700	TB115	0.10	261-9760	TC115	0.20	261-9760	TC115	0.20
1	Gate Bolt Nut	260-9755	TB114	0.10	261-9750	TC114	0.20	261-9750	TC114	0.20
4	Taper Pin	261-7119	TB119	0.20	261-7119	TB119	0.20	261-7119	TB119	0.20
2	Retaining Ring	260-1990	TB122	0.20	260-1990	TB122	0.20	260-1990	TB122	0.20
4	Grease Fitting	260-9890	TB123	0.10	260-9890	TB123	0.10	260-9890	TB123	0.10
4	Shaft Bushing	260-9400	TB124	2.00	261-9400	TC124	0.20	261-9400	TC124	0.20
2	Spacer	260-9410	TB126	0.10	261-9420	TC126	0.10	261-9420	TC126	0.10
1	Safety Latch	14-2000	TB135	0.75	14-2000	TB135	0.75	14-2000	TB135	0.75
1	Safety Latch Bolt	261-9710	TB136	0.10	261-9710	TB136	0.10	261-9710	TB136	0.10
1	Air Cylinder Ass'y (Bronze)	261-3902	TB140-N	12.5	261-3902	TB140-N	12.5	261-3902	TB140-N	12.5
1	Air Cylinder Repair Kit	261-8400	TB140-R	1.50	261-8400	TB140-R	1.50	261-8400	TB140-R	1.50
1	Male Q/C Coupling		TB128			TB128			TB128	
1	Flow Control Q/C Coup		TB130			TB130			TB130	
Accessories										
1	AC Unit w/Valve, Pressure Regulator & Gauges	261-9900	TB410-P	25.0	261-9900	TB410-P	25.0	261-9900	TB410-P	25.0
1	Air Hose 25' Q/DC	261-9910	TB410	5.00	261-9910	TB410	5.00	261-9910	TB410	5.00
1	Air Foot Control Valve	261-9905	NA	10.0	261-9905	NA	10.0	261-9905	NA	10.0



**Model GS-60 Tubing Spider Assembly P/N 26-1005
(Less Foot Valve, Slip Assembly and Inserts)**

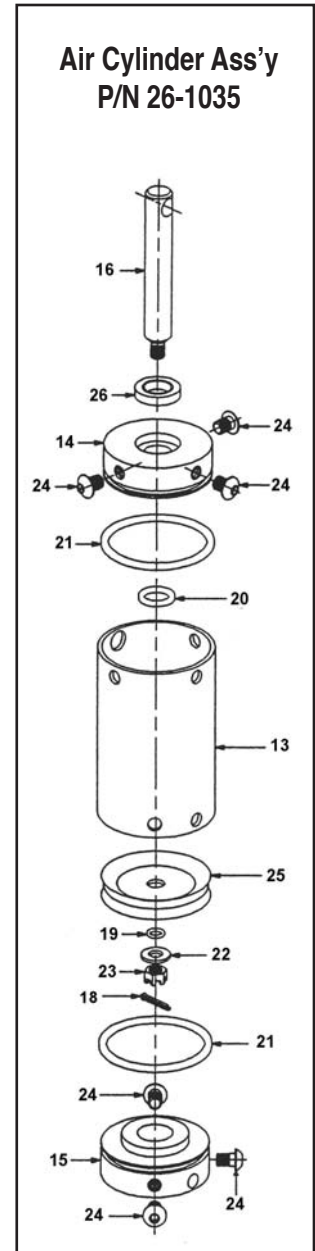
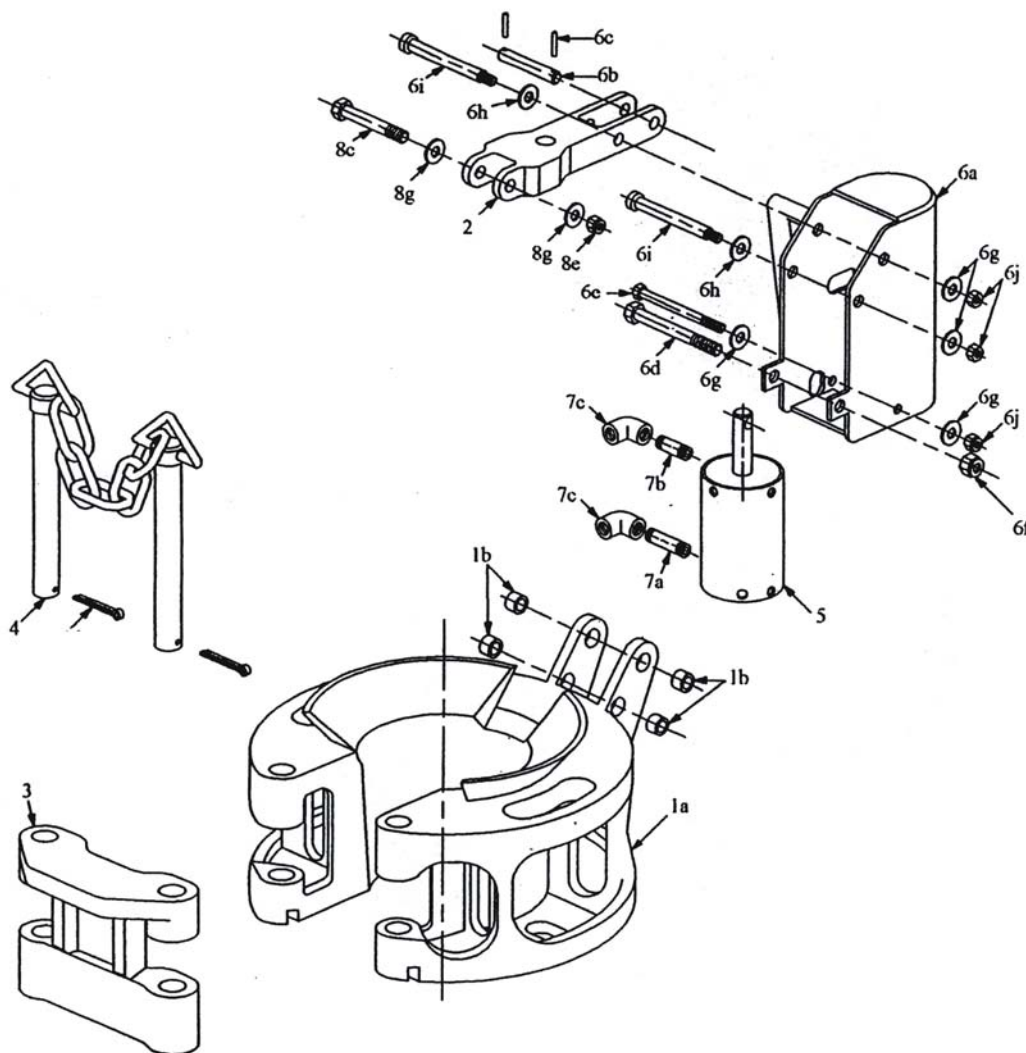



GS-60 Tubing Spider Assembly & Parts (Less Slip Assembly & Inserts)

Ref.	Part #	OEM	Description	Qty	Wt.
	26-1000		Spider Ass'y, w/Plain Gate, Air Cylinder & Foot Valve Only	1	275
	26-1005	61005-100	Spider Ass'y, w/Air Cylinder (Less Foot Valve & Slip Body)	1	260
3	26-1015	61000	Spider Bowl with Tension Bushings Only	1	215
4	26-1015-2	992550-01-01	Steel Tension Bushing	4	0.03
5	26-1020	61010	Lift Arm	1	4.00
6	26-1025	61015	Gate	1	15.6
	26-1030	61022-100	Gate Pin Assembly	1	4.30
8	26-1030-1	61013	Gate Pin	2	2.10
9	26-1030-2	61020	Bendable Chain Loop	2	0.07
10	26-1030-3	992445-04	Double Loop Coil Chain, #2 Zinc Plated	1	0.42
12	26-1035	61024-100	Air Cylinder Assembly	1	5.50
13	26-1035-1	61014	Brass Cylinder Barrel	1	
14	26-1035-2	61016	Cylinder End	1	
15	26-1035-3	61017	Cylinder Cap	1	
16	26-1035-4	61018	Cylinder Stem	1	
	26-1040	61032-100	Air Cylinder Repair Kit	1	1.00
18	97-90-0406	992012-09	Cotter Pin	1	0.01
19	26-1040-2	992154-012	O-Ring	1	0.01
20	26-1040-3	992154-210	O-Ring	1	0.01
21	26-1040-4	992154-232	O-Ring	2	0.01
22	97-61-1200	992155-04	Flat Washer	1	0.01
23	26-1040-6	992213-06	Finished Slotted Hex Nut	1	0.25
24	26-1040-7	992224-61	Button Head Capscrew	6	0.05
25	26-1040-8	992548-23	Piston & Seal Assembly	1	0.01
26	26-1040-9	992549-01	Wiper Seal	1	0.01
	26-1045	61025-100	Mounting System	1	
28	26-1045-1	91021-200	Cylinder Housing	1	12.2
29	26-1045-2	61030-100	Bolt Kit, Cylinder Mounting & Lift Arm	1	
30	26-1045-3	61012	Pivot Pin	1	0.17
31	97-90-0416	992011-98	Cotter Pin for Pivot Pin	2	0.02
32	97-05-1628-25	61019	Lift Arm Bolt	1	0.12
34	97-01-1240-21	992033-18	Hex Head Capscrew	1	0.34
35	97-42-1600-25	992089-09	Nut with Nylok	1	0.04
36	97-61-1200	992155-04	Flat Washer	4	0.01
37	97-60-1600	992155-06	SAE Flat Washer	4	0.01
38	97-12-1236-21	992218-16	Socket Head Shoulder Screw	2	0.30
39	97-41-1200-21	992501-11	Flex Lock Hex Nut	3	0.02
41	26-1050-1	992349-004	Pipe Nipple	4	0.08
42	26-1050-2		M-Style Female Connector, 1/4"	2	0.05
43	26-1050-3	992186-04	90° Elbow	2	0.11



Tubing Spider Foot Control Assembly

Ref.	Part #	OEM	Description	Qty	Wt. Each
70	26-1055	61038-100	Foot Control Valve Ass'y with Cover, Hose & Regulator	1	20.00
71	26-1055-1	65200-100	Cover with Pneumatic Foot Control Valve Assembly	1	12.00
72	26-1055-2	65300	Pneumatic Hose Assembly (15 Foot)	2	3.00
73	26-1055-3	65410-100	In-line Pneumatic Regulator with Filter Assembly	1	2.00



Guiberson T-60 Tubing Spiders

- The T-60 is rated at 60 tons. • Can handle 25,000 feet of 2-3/8" tubing.
- Accommodates pipe from 1" (1.315") to 4-1/2".

Cat. #	Ref. #	Description	Wt. Ea.	Qty. Req.	Box
Replacement Tool Assemblies					
265-1000	62454	T-60 Spider w/Plain Gate, Foot Valve & 2-7/8" Slip Body (Less Ins.)	310	1	NA
265-1005	67580	T-60 Spider w/Plain Gate & 2-7/8" Slip Body Only (Less Inserts)	296	1	NA
265-1020	62458	T-60 Spider w/Plain Gate, Foot Valve & 3-1/2" Slip Body (Less Ins.)	310	1	NA
265-1025	NA	T-60 Spider w/Plain Gate & 3-1/2" Slip Body Only (Less Inserts)	296	1	NA
Replacement Slip Bodies					
265-1615	62461	Slip Body Ass'y, 2-7/8" (Less Inserts)	36	1	1
265-1620	62462	Slip Body Ass'y, 3-1/2" (Less Inserts)	36	1	1
Replacement Parts					
265-8405	56812	Slip Kit for T-60, 2 Bolt Ass'y with 2 Springs	1.5	1	AR
265-9505	54219	Slip Spring	0.3	2	AR
265-9700	NA	Slip Bolt Assembly	0.7	2	AR
97-12-1636-21	NA	Shoulder Bolt, 4-1/2"	0.4	1	AR
97-60-1600	NA	Washer, Flat 1/2" SAE Z 1	0.1	1	A/R
97-61-1200	NA	Washer, Flat 3/8" USS Z 1	0.1	1	A/R
97-41-1200-21	NA	Nut, Hex 3/8"-16 Flexloc TP Z1	0.1	1	A/R
Replacement Inserts					
265-0802	62474	Insert for Guiberson, 2-7/8" x 1" (1.315")	0.75	18	18
265-0803	62475	Insert for Guiberson, 2-7/8" x 1-1/4" (1.660")	0.63	18	18
265-0804	62476	Insert for Guiberson, 2-7/8" x 1-1/2" (1.900")	0.59	18	18
265-0806	62478	Insert for Guiberson, 2-7/8" x 2-1/16" (2.062")	0.56	18	18
265-0807	42586	Insert for Guiberson, 2-7/8" x 2-3/8"	0.47	18	18
265-0808	42587	Insert for Guiberson, 2-7/8" x 2-7/8"	0.34	18	18
265-1313	42588	Insert for Guiberson, 3-1/2" x 3-1/2"	0.34	18	18
97-90-1010	NA	Cotter Pin for Inserts	0.02	6	6

Oil Country Type G Tubing Spiders

Cat. #	Ref. #	Description	Wt. Ea.	Qty. Req.	Box
Replacement Tool Assemblies					
268-1000	61000-100	Spider Ass'y w/Plain Gate, Foot Valve & 3-1/2" Slip Body (Less Ins.)	310	1	NA
268-1005	NA	Spider Ass'y w/Plain Gate & 3-1/2" Slip Body Only (Less Inserts)	296	1	NA
268-1020	NA	Spider Ass'y w/Plain Gate, Foot Valve & 4-1/2" Slip Body (Less Ins.)	310	1	NA
268-1025	NA	Spider Ass'y w/Plain Gate & 4-1/2" Slip Body Only (less inserts)	296	1	NA
Replacement Slip Bodies					
268-1613	61003-100	Slip Body Oil Country G, 3-1/2" (Less Inserts)	29.0	1	A/R
268-1621	61039-100	Slip Body Oil Country G, 4-1/2" (Less Inserts)	40.0	1	A/R
Replacement Parts					
268-1800	61008	Insert Retainer Pin	0.05	1	A/R
97-90-0510	992012-43	Cotter Pin for Inserts	0.06	3	A/R
268-9400	N/A	Mounting Bolt Bushing	0.50	1	A/R
268-8450	NA	Slip Body Bolt & Spring Kit	2.00	1	A/R
97-12-1636-21	NA	Shoulder Bolt	1.00	2	A/R
268-9500	61033	Slip Body Spring, 3-1/2"	0.50	2	A/R
268-9505	61044	Slip Body Spring, 4-1/2"	0.50	2	A/R
97-61-1200	992155-04	Flat Washer	0.10	2	A/R
97-41-1200-21	992501-11	Flex Lock Hex Nut	0.25	55	A/R
Replacement Inserts - 3-1/2" Slip Body					
268-1302	61041-02	Insert For Oil Country G, 3-1/2" x 1" (1.315")	7.0	3	3
268-1303	61041-03	Insert For Oil Country G, 3-1/2" x 1-1/4" (1.660")	5.6	3	3
268-1304	61041-04	Insert For Oil Country G, 3-1/2" x 1-1/2" (1.900")	5.2	3	3
268-1306	61041-05	Insert For Oil Country G, 3-1/2" x 2-1/16"	4.5	3	3
268-1307	61006-01	Insert For Oil Country G, 3-1/2" x 2-3/8"	4.0	3	3
268-1308	61006-02	Insert For Oil Country G, 3-1/2" x 2-7/8"	3.5	3	3
268-1313	61006-03	Insert For Oil Country G, 3-1/2" x 3-1/2"	3.0	3	3
Replacement Inserts - 4-1/2" Slip Body					
268-2113	61040-01	Insert For Oil Country G, 4-1/2" x 3-1/2"	8.0	3	3
268-2117	61040-02	Insert For Oil Country G, 4-1/2" x 4"	6.0	3	3
268-2121	61040-03	Insert For Oil Country G, 4-1/2" x 4-1/2"	3.0	3	3



Solid & Plate Type Sucker Rod Elevator

Rod Elevators available to handle rod sizes from 1/2" through 1-1/8". Elevator assemblies use a spring loaded latch and the rod can only be released by the operator. The bail and body is made from alloy steel and heat treated for maximum strength and durability. All steel specifications are certified and rod elevator is rated at 20 ton capacity.

Cat. #	Rod Size	Wt. Lbs. Ea.
Solid Body Elevator Assembly		
290-1000	5/8" to 3/4"	30.0
290-1010	3/4" to 7/8"	30.0
290-1020	1"	30.0
Plate Type Elevator Assembly		
290-1040	1/2" to 1-1/8"	30.0

Cat. #	Description	Qty. Req.	Wt. Ea.
Replacement Parts			
290-2000	Back Latch	2	0.50
290-2010	Front Latch for 5/8" to 3/4"	2	0.50
290-2020	Front Latch for 3/4" to 7/8"	2	0.50
290-2030	Front Latch for 1"	2	0.50
290-9500	Spring	2	0.10
290-9950	Roll Pin	4	0.10
290-1900	Retainers	2	0.10
Expendable Parts			
290-9900	Replacement Plate, 1/2"	2	0.50
290-9905	Replacement Plate, 5/8" to 3/4"	2	0.50
290-9910	Replacement Plate, 3/4" to 7/8"	2	0.50
290-9915	Replacement Plate, 1"	2	0.50
290-9920	Replacement Plate, 1-1/8"	2	0.50
290-9700	Screw for Plates	4	0.20

